

You can visit the website
by scanning the QR code.



www.hyundai-mh.com / 2019. 09 Rev. 14

HYUNDAI
MATERIAL HANDLING

MOVING YOU FURTHER

16-18
20B-9F



Some of the photos may include optional equipment

HYUNDAI
MATERIAL HANDLING

Your satisfaction is our priority.

Robust AC technology! Hyundai's 9-series small battery forklift

Hyundai introduces a new line of 9-series battery forklifts.

The newly designed four-wheel counterbalance forklift maximizes productivity by enabling comfortable driving and easy maintenance.

Work efficiency & productivity

- Prolonged Battery use : Regenerative braking
- Powerful and precise driving performance of a dual drive motor
- Optimized performance mode setting (H,N,E)
- Curve control
- Electronic fingertip control lever (OPT)

Durability & reliability

- AC motor exclusive - IP65 ZAPI controller
- Semi-permanent wet disc brake
- IP43 AC motor

Safety

- Anti-roll back (ABS) system
- Turtle mode & maximum speed control
- Operator Presence Sensing System (Optional)
- Panoramic rear view mirror

Maintenance

- Self diagnostics function
- Password starting system
- Brake oil level sensing system





Power & Performance

High Efficiency & Optimal Performance

An efficient, smooth running and compact design provides enhanced performance and outstanding productivity.

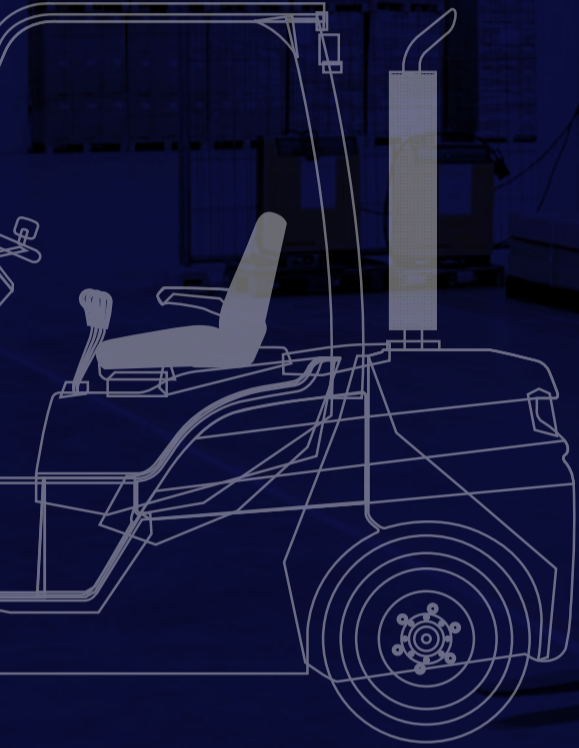

Some of the photos may include optional equipment

Strong driving power – Dual drive motor system

The dual drive motor system consists of two separately controlled drive motors. Unlike the single drive motor system, it prevents the wheels from spinning even when the grip force of the left and right wheels is different. In addition, it enables strong drive performance even on a dirty road. As the pivot point is the axle of the wheels, the dual system enables relatively small turning radius compared to the single system, thus improving efficiency in small worksites.



Some of the photos may include optional equipment

Excellent driving & work performance

The combination of best-in-class drive and pump motors and the latest ZAPI AC controller allow for quick and agile driving and ideal operation speed, optimizing efficiency of loading/unloading.

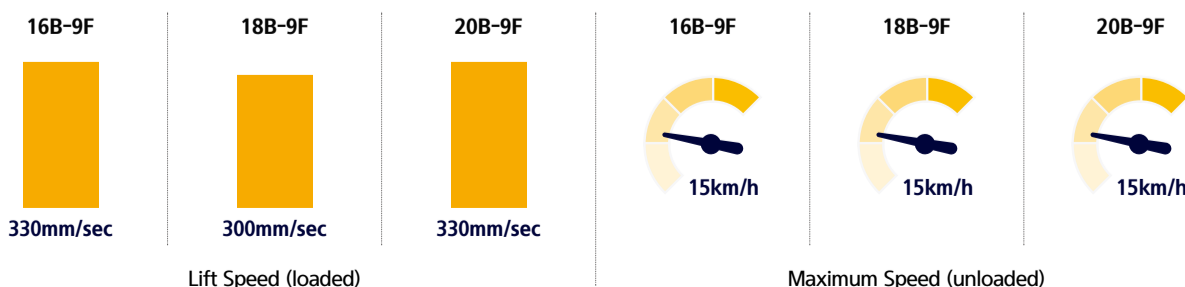

Robust and economical AC motor

Drive and pump motors using our AC technology provide great controllability and durability, compared to DC motors. Also, AC motors without the commutator and brushes cost less to maintain. In addition, it has been tested and passed for IP43 protection rating.



New ZAPI controller

The almost noiseless 8 khz (high frequency) ZAPI controller enables high efficiency control and protects the system from low and high voltages and overheating.



Wet disc brake

The semi-permanent wet disc brake provides constant braking force without overheating even when used for long hours of repetitive work, thus improving work efficiency. Without requiring brake linings, which needs regular replacement, maintenance costs are relatively low.



Optimized operation mode setting

Through the cluster and the performance selection function of ZAPI controller, the operator can select an optimal performance mode depending on working conditions, worksite size and operator proficiency. **H** (High), **N** (Normal), **E** (Economic)



Curve control

Curve control limits travel speed based on turning radius for a smooth, precise turning operation for the driver.



Prolonged Battery use

When the operator's foot is lifted from the accelerator, the kinetic energy is converted to electrical energy and stored in batteries. The operator can stop the vehicle with the energy generated from the energy conversion.



Easy & Comfort

Optimized Ergonomics & Fast and Easy Maintenance

An ergonomically designed workspace for operator provides the best comfort and easy access for maintenance.



Some of the photos may include optional equipment

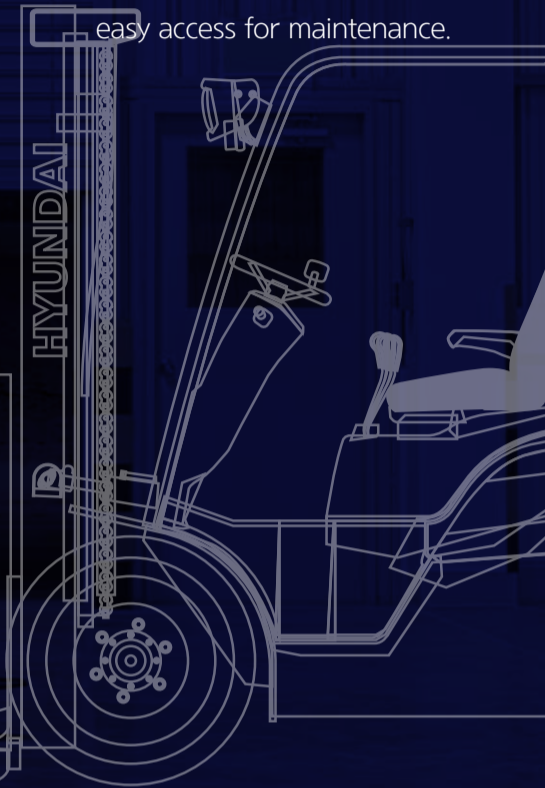

Ergonomically designed workspace

Ergonomic design focusing on operator convenience and maneuverability further enhances work efficiency. Easily operable levers and pedals, adjustable handle, suspension seat and a large multi-functional cluster dashboard allow comfortable and efficient driving.

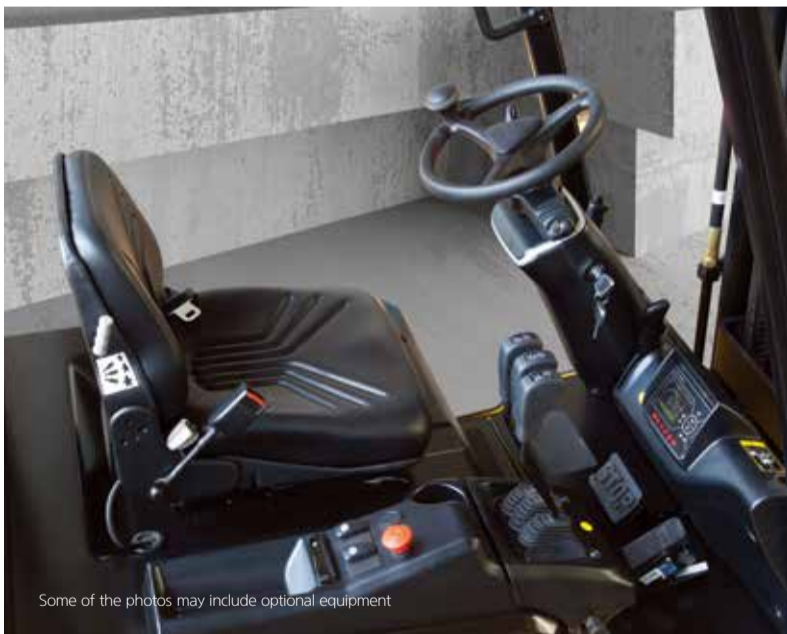

Some of the photos may include optional equipment



Grammer seat

An adjustable ergonomic seat provides unmatched comfort. The adjustable armrest further reduces operator fatigue.

- ELR(Emergency Locking Retractable) type seat belt
- Seat heater (STD) & headrest (OPT)

3.5 inch LCD color monitor

The 3.5 inch TFT LCD color monitor indicates speed, steering angle & driving direction, battery charge level and hour meter & working mode, thus allowing easy and efficient control for the operator. In addition, diagnostic error codes allow easy fault diagnosis.



Main functions

- Steering wheel position & driving direction
- Turtle mode
- Driving speed (Digital)
- Battery discharge indicator
- High temp warning lamp
- Wrench warning light
- Roll up
- ESC
- Menu / Scroll left
- Performance / Scroll right
- Enter
- Turtle / Scroll down

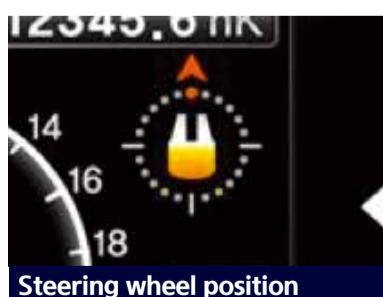

Steering wheel position

A steering sensor is applied to the king pin of the rear axle, communicates to the LCD color monitor to show the direction of the vehicle as it relates to the angle of the steer wheel.

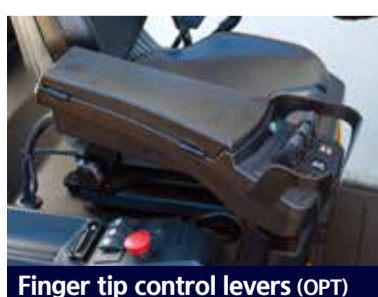

Finger tip control levers (OPT)

Ergonomically designed electrical fingertip control levers for improved operator comfort and productivity. The armrest can be adjusted for operator comfort.



Adjustable tilting handle

The handle angle can be adjusted with the lever on the right side of the steering wheel to suit the operator's physique and driving habit.



Easy maintenance of battery

The battery cover opens fully with the assistance of a gas strut that locks when fully opened to give easy access to battery and prevent the hood from dropping.



Brake oil reservoir with level sensor

The enhanced brake oil reservoir, located in the upper left dash is equipped with an electronic level sensor that shows the level in the LCD color monitor.



Secure & Safety

Advanced Safety

The safely designed driver's space makes your operating more comfortable.

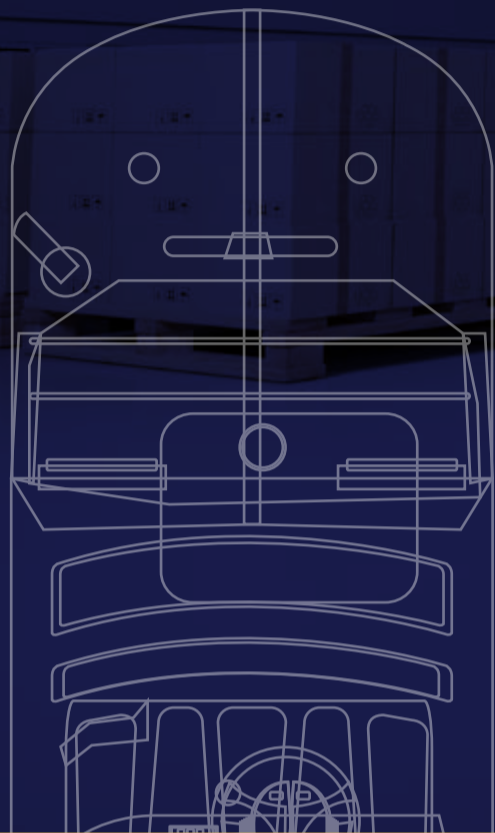

Some of the photos may include optional equipment

Great visibility for safe operation

The optimized lift cylinder array design provides a clear, wide field of vision for the operator. A rear camera(OPT) and panoramic mirror expands the driver's view when backing up.



Some of the photos may include optional equipment



Strong overhead guard

Exceeding ISO6055 regulations, the overhead guard offers great protection combined with excellent all around visibility.



Panoramic mirror

The panoramic mirror expands the driver's view when backing up.

Speed limit setting

The operator can set and limit the maximum speed given the curve & congestion of an aisle and the shape of the load.

Password starting system

The operator can set a password to prevent vehicle theft and possible safety accidents in case the vehicle is used by an unauthorized person.

Safety features

The adoption of a high-sensitivity sensor and advanced safety system can prevent the safety accidents.



Anti-Roll Back system

Anti roll-back system offers protection against the machine rolling back on a ramp in combination with exceptional ramp start capabilities.

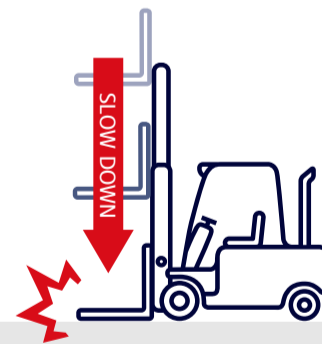

Fork safety features

As the forks are being lowered, a down-control valve maintains a controlled descent speed. The down-safety valve prevents forks from dropping down in case of sudden damage of hydraulic line.

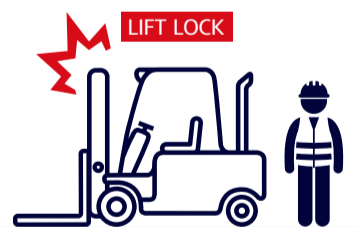

Operator presence sensing system (OPSS)

When operator is not in seat, the mast cylinder does not function even if the action lever is operated.



Strengthened work safety

Rear LED lights and halogen lights offer excellent visibility even during night operations. Safety has been increased by installing an additional reflector on the counterweight.

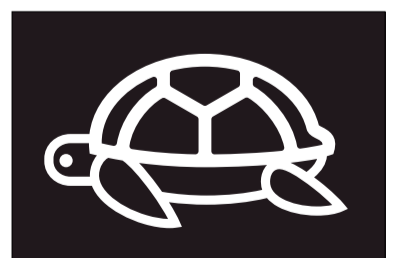

Turtle mode

When selecting the turtle mode while working in narrow and congested workplace, the travel speed is reduced at a preset speed.

Fleet Management System(Hi FLEET)(OPT)

Hi FLEET, Hyundai material handling's fleet management system, is the optimal operation solution for a fleet of forklifts. It connects driver and vehicle in real time.



You can see the video by scanning the QR code.

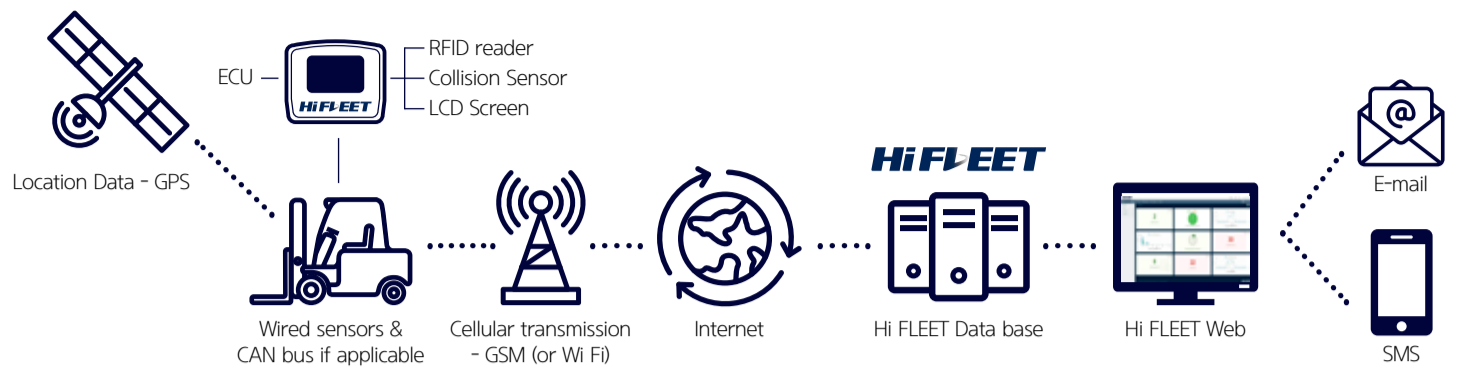

DRIVER MANAGEMENT

It is possible to certify drivers and manage their work through RFID, PIN password.

VEHICLE MANAGEMENT

You can check the operating time, battery status, and location information in real time.



SAFETY MANAGEMENT

You can check the driver's conditions and vehicle status before starting work and manage the speed and collision.

MAINTENANCE

You can keep your vehicles in optimal condition by notifying the vehicle's maintenance interval and fault codes.

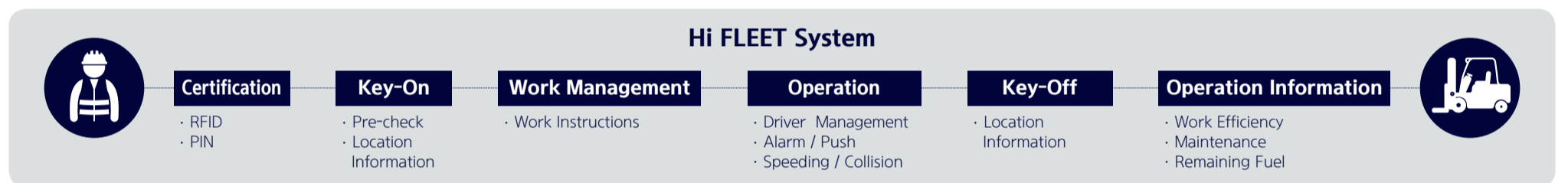

New 9 Series Mast Specification

16/18/20B-9F

16B-9F

Mast Type	Maximum Fork Height	Overall Height (Lowered)	Free lift height			Tilt Angle		Load capacity Without side shift	Load capacity With side shift	Truck Weight (Unloaded)	
			With Load Backrest	Without Load Backrest	Without Load Backrest (3/4-SPOOL)	Fwd	Bwd				
											mm
2-STAGE LIMITED FREE LIFT	V250	2525	1720	35	35	35	5	7	1600	1530	3033
	V270	2725	1820				5	7	1600	1530	3045
	V300	3025	1970				5	7	1600	1530	3065
	*V330	3325	2120				5	7	1600	1530	3085
	V350	3525	2220				5	7	1600	1530	3098
	V370	3725	2320				5	7	1600	1530	3111
	V400	4025	2470				5	7	1550	1490	3136
	V450	4525	2820				5	5	1500	1440	3203
	V500	5025	3070				5	5	1400	1340	3237
	V550	5525	3320				5	5	1350	1300	3257
2-STAGE FULL FREE LIFT	VF/VS300	3025	1970	972	1479	1339	5	5	1600	1530	3104
	VF/VS330	3325	2120	1122	1629	1489	5	5	1600	1530	3125
	VF350	3525	2220	1222	1729	1589	5	5	1600	1530	3140
3-STAGE FULL FREE LIFT	TF370	3735	1770	772	1205	1065	5	5	1550	1490	3181
	TF400	4035	1870	872	1305	1165	5	5	1500	1440	3201
	TF430	4335	1970	972	1405	1265	5	5	1475	1420	3220
	TF450	4535	2070	1072	1555	1415	5	5	1450	1390	3240
	TF470	4735	2120	1122	1555	1415	5	5	1425	1370	3250
	TF500	5035	2220	1222	1655	1515	5	5	1400	1340	3270
	TF550	5535	2420	1422	1905	1765	5	5	1325	1300	3310
	TF600	6035	2620	1622	2105	1965	5	5	1250	1200	3373
	TF650	6535	2820	1822	2285	2145	3	3	1050	1000	3418
	TF700	7035	3020	2022	2465	2325	3	3	900	860	3457
	TS430	4335	1970	972	1307	1137	5	5	1475	1420	3220
	TS450	4535	2070	1072	1457	1287	5	5	1450	1390	3240
	TS470	4735	2120	1122	1457	1287	5	5	1425	1370	3250
	TS500	5035	2220	1222	1557	1387	5	5	1400	1340	3270
	TS550	5535	2420	1422	1807	1637	5	5	1325	1300	3310
	TS600	6035	2620	1622	2007	1837	5	5	1250	1200	3373
	TS650	6535	2820	1822	2187	2017	3	3	1050	1000	3418
TS700	7035	3020	2022	2367	2197	3	3	900	860	3457	

※ : Standard

18B-9F

Mast Type	Maximum Fork Height	Overall Height (Lowered)	Free lift height			Tilt Angle		Load capacity Without side shift	Load capacity With side shift	Truck Weight (Unloaded)	
			With Load Backrest	Without Load Backrest	Without Load Backrest (3/4-SPOOL)	Fwd	Bwd				
											mm
2-STAGE LIMITED FREE LIFT	V250	2525	1729	35	35	35	5	7	1800	1730	3160
	V270	2725	1829				5	7	1800	1730	3172
	V300	3025	1979				5	7	1800	1730	3192
	*V330	3325	2129				5	7	1800	1730	3212
	V350	3525	2229				5	7	1800	1730	3225
	V370	3725	2329				5	7	1800	1730	3238
	V400	4025	2479				5	7	1800	1730	3262
	V450	4525	2829				5	5	1750	1680	3330
	V500	5025	3079				5	5	1650	1590	3363
	V550	5525	3329				5	5	1600	1540	3383
3-STAGE FULL FREE LIFT	VF/VS300	3025	1979	981	1479	1339	5	5	1800	1730	3230
	VF/VS330	3325	2129	1131	1629	1489	5	5	1800	1730	3252
	VF350	3525	2229	1231	1729	1589	5	5	1800	1730	3267
	TF370	3735	1779	781	1205	1065	5	5	1800	1730	3307
	TF400	4035	1879	881	1305	1165	5	5	1750	1690	3327
	TF430	4335	1979	981	1405	1265	5	5	1725	1660	3347
	TF450	4535	2079	1081	1555	1415	5	5	1700	1640	3366
	TF470	4735	2129	1131	1555	1415	5	5	1650	1590	3377
	TF500	5035	2229	1231	1655	1515	5	5	1600	1540	3397
	TF550	5535	2429	1431	1905	1765	5	5	1500	1450	3436
	TF600	6035	2629	1631	2105	1965	5	5	1350	1300	3500
	TF650	6535	2829	1831	2285	2145	3	3	1300	1250	3545
	TF700	7035	3029	2031	2499	2359	3	3	1050	1010	3583
	TS430	4335	1979	981	1307	1137	5	5	1725	1660	3347
	TS450	4535	2079	1081	1457	1287	5	5	1700	1640	3366
	TS470	4735	2129	1131	1457	1287	5	5	1650	1590	3377
	TS500	5035	2229	1231	1557	1387	5	5	1600	1540	3397
TS550	5535	2429	1431	1807	1637	5	5	1500	1450	3436	
TS600	6035	2629	1631	2007	1837	5	5	1350	1300	3500	
TS650	6535	2829	1831	2187	2017	3	3	1300	1250	3545	
TS700	7035	3029	2031	2367	2197	3	3	1050	1010	3583	

※ : Standard

20B-9F

Mast Type	Maximum Fork Height	Overall Height (Lowered)	Free lift height			Tilt Angle		Load capacity Without side shift	Load capacity With side shift	Truck Weight (Unloaded)	
			With Load Backrest	Without Load Backrest	Without Load Backrest (3/4-SPOOL)	Fwd	Bwd	500mm LC	500mm LC		
			mm	mm	mm	deg	deg	kg	kg		
2-STAGE LIMITED FREE LIFT	V250	2530	1729	40	40	40	5	7	2000	1930	3362
	V270	2730	1829				5	7	2000	1930	3375
	V300	3030	1979				5	7	2000	1930	3394
	*V330	3330	2129				5	7	2000	1930	3415
	V350	3530	2229				5	7	2000	1930	3428
	V370	3730	2329				5	7	2000	1920	3440
	V400	4030	2479				5	7	2000	1920	3465
	V450	4530	2829				5	5	1925	1860	3532
	V500	5030	3079				5	5	1850	1790	3566
V550	5530	3329	5	5	1775	1710	3586				
2-STAGE FULL FREE LIFT	VF/VS300	3030	1979	986	1484	1280	5	5	2000	1930	3433
	VF/VS330	3330	2129	1136	1634	1430	5	5	2000	1930	3454
	VF350	3530	2229	1236	1734	1530	5	5	2000	1930	3470
3-STAGE FULL FREE LIFT	TF370	3740	1779	786	1210	1006	5	5	2000	1930	3510
	TF400	4040	1879	886	1310	1106	5	5	1950	1880	3530
	TF430	4340	1979	986	1410	1206	5	5	1925	1860	3550
	TF450	4540	2079	1086	1510	1306	5	5	1900	1840	3569
	TF470	4740	2129	1136	1560	1356	5	5	1850	1790	3580
	TF500	5040	2229	1236	1660	1456	5	5	1800	1750	3600
	TF550	5540	2429	1436	1910	1756	5	5	1700	1640	3639
	TF600	6040	2629	1636	2110	1956	5	5	1600	1540	3703
	TF650	6540	2829	1836	2290	2116	3	3	1300	1250	3747
	TF700	7040	3029	2036	2504	2344	3	3	1150	1100	3786
	TS430	4340	1979	986	1312	980	5	5	1925	1860	3550
	TS450	4540	2079	1086	1462	1180	5	5	1900	1840	3569
	TS470	4740	2129	1136	1462	1130	5	5	1850	1790	3580
	TS500	5040	2229	1236	1562	1230	5	5	1800	1750	3600
	TS550	5540	2429	1436	1812	1530	5	5	1700	1640	3639
	TS600	6040	2629	1636	2012	1730	5	5	1600	1540	3703
	TS650	6540	2829	1836	2192	1890	3	3	1300	1250	3747
TS700	7040	3029	2036	2372	2050	3	3	1150	1100	3786	

※ : Standard

New 9 Series

Load Capacity

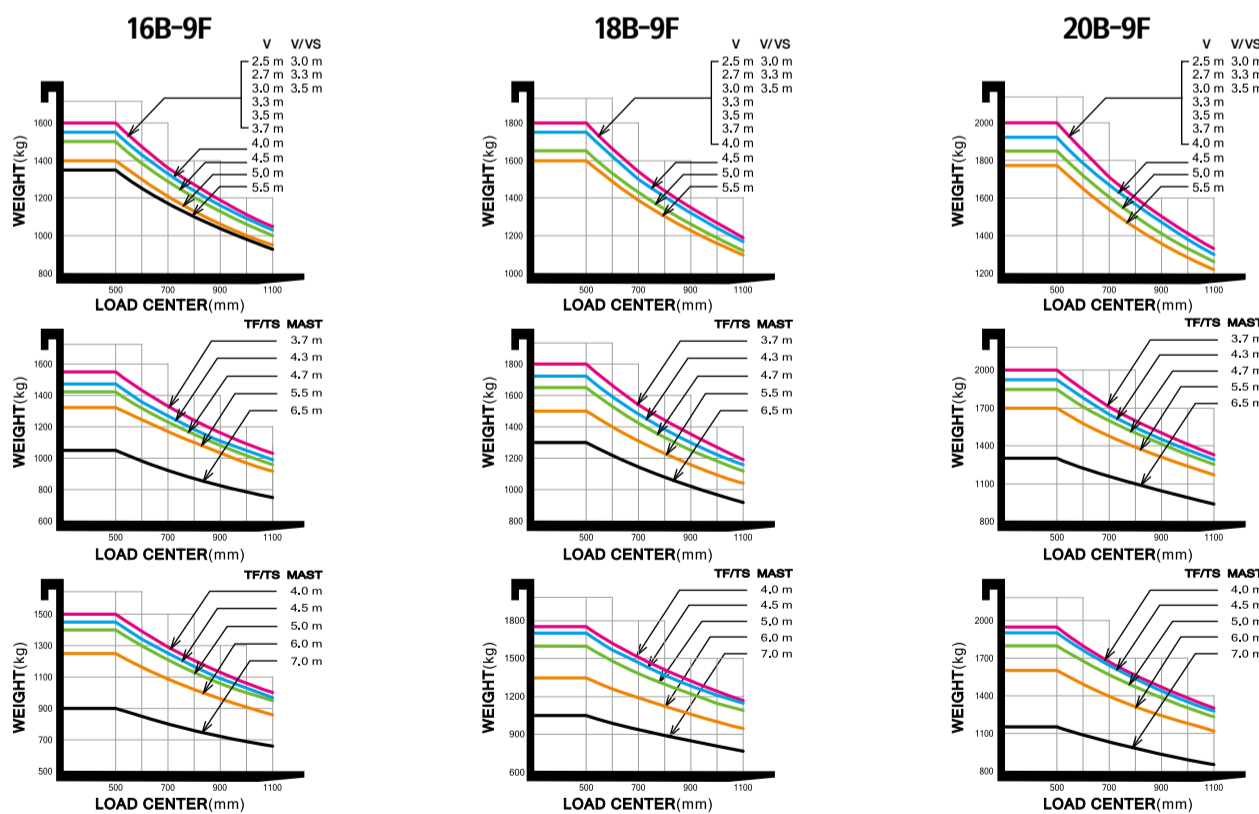

Various Attachments

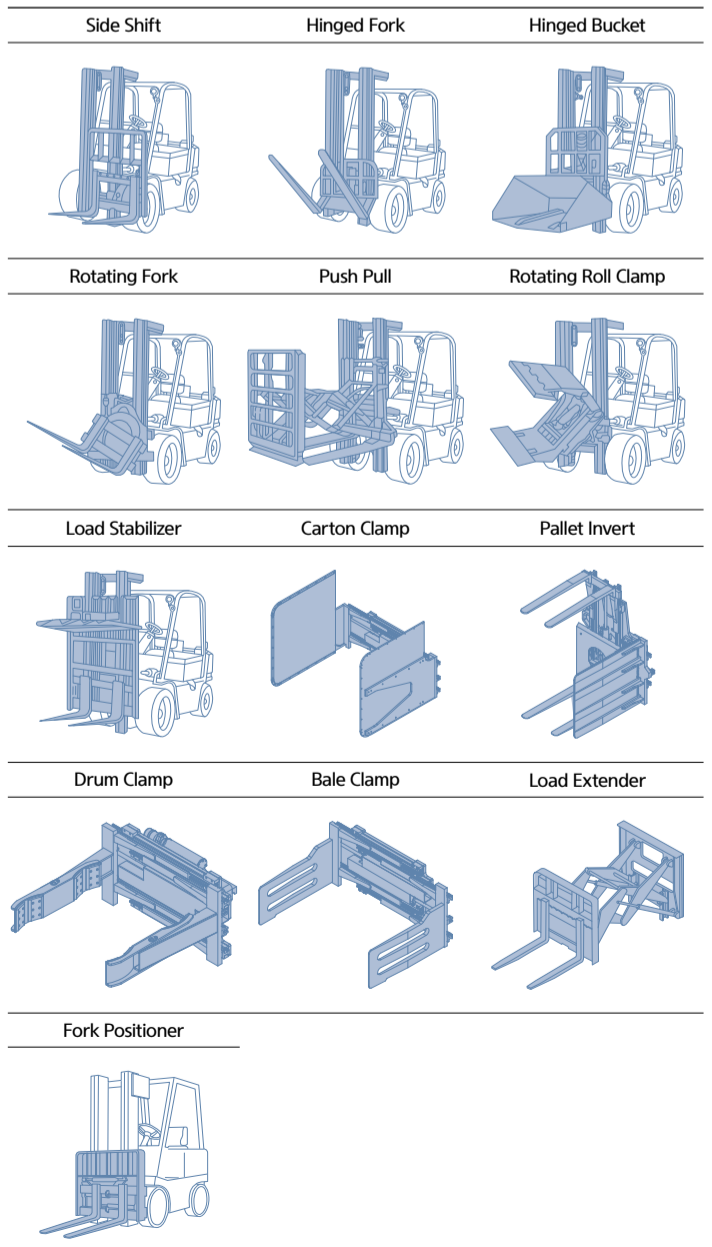

Optional Items

- Fork (mm)
16 / 18B-9F : 35X100X750, 850, 900(STD), 1050, 1200, 1350, 1500
20B-9F : 40X100X900(STD), 950, 1000, 1050, 1150, 1200, 1350, 1500, 1600
- Integral Sideshift / Sideshift
- Tire : SOLID(STD) / Non-marking / Wide tire [16B-9F : Front tire (200 / 50-10)]
- Seat : semi suspension seat (STD)
Full suspension seat (Armrest, Backrest extension, Heating, Buckle SW)
- M.C.V : 2-Spool (STD), 3-Spool, 4-Spool
- Beacon Lamp
- Work Lamp and rear combination lamp
- Side Mirror
- OPSS : Mast
- Cold Storage (for -30° c cold working environments)
- Cabin (Fine Top)
- Load Backrest (LBR)

Specification



Identification					
1.1	Manufacturer		Hyundai		
1.2	Model	16B-9F	18B-9F	20B-9F	
1.3	Power type	Electric	Electric	Electric	
1.4	Type of operation	Seated	Seated	Seated	
1.5	Load capacity	Q kg	1,600	1,800	2,000
1.6	Load center distance	c mm	500	500	500
1.8	Load distance, center of front axle to fork	x mm	360	360	365
1.9	Wheelbase	y mm	1,355	1,440	1,440
Weights					
2.1	Service weight (including battery)	kg	3,085	3,214	3,394
2.2	Axle loading, loaded front / rear	kg	4,106 / 578	4,437 / 577	4,770 / 624
2.3	Axle loading, unloaded front / rear	kg	1,491 / 1,594	1,562 / 1,652	1,569 / 1,825
Tires					
3.1	Tires : solid rubber(V), superelastic(SE), pneumatic(P), polyurethane(PE)		SE	SE	SE
3.2	Front Tire size (Ø×width)		18×7-8	200 / 50-10	200 / 50-10
3.3	Rear tire size (Ø×width)		16×6-8	16×6-8	16×6-8
3.5	Wheels, number front rear (x = driven wheels)		2× / 2	2× / 2	2× / 2
3.6	Track width, front	mm	895	905	905
3.7	Track width, rear	mm	880	880	880
Dimensions					
4.1	Mast / fork carriage tilt forward / backward	degrees(°)	5 / 7	5 / 7	5 / 7
4.2	Lowered mast height	h1 (mm)	1,970	1,979	1,979
4.3	Free lift height	h2 (mm)	35	35	40
4.4	Lift height	h3 (mm)	3,025	3,025	3,030
4.5	Extended mast height	h4 (mm)	4,020	4,020	4,020
4.7	Overhead guard (cab) height	h5 (mm)	2,065	2,065	2,065
4.8	Seat height / Standing height	h7 (mm)	1,090	1,090	1,090
4.12	Coupling height	h10 (mm)	250	250	250
4.19	Overall length	l1 (mm)	2,935	3,020	3,030
4.20	Length to face of forks	l2 (mm)	2,035	2,120	2,130
4.21	Overall width	b1 (mm)	1,074	1,105	1,105
4.22	Fork dimensions	s / e / l (mm)	35×10×900	35×100×900	40×100×900
4.23	Fork carriage ISO 2328, class / type A, B		II/A	II/A	II/A
4.24	Fork-carriage width	b3 (mm)	1,006	1,006	1,006
4.31	Ground clearance, loaded, under mast	m1 (mm)	85	94	94
4.32	Ground clearance, centre of wheelbase	m2 (mm)	90	90	100
4.33	Aisle width for pallets 1,000×1,200 crossways (L×W)	Ast (mm)	3,352	3,427	3,447
4.34	Aisle width of pallets 800×1,200 crossways (W×L)	Ast (mm)	3,495	3,575	3,595
4.35	Turning radius	Wa (mm)	1,710	1,795	1,810

Performance Data					
5.1	Travel speed, loaded / unloaded	km/h	14 / 15	14 / 15	14 / 15
5.2	Lift speed, loaded / unloaded	mm/s	330 / 500	300 / 500	330 / 500
5.3	Lowering speed, loaded / unloaded	mm/s	500 / 450	500 / 450	500 / 450
5.6	Max. drawbar pull, loaded / unloaded S2 5min	N	11,550 / 11,345	12,035 / 10,835	12,020 / 10,805
5.8	Max. gradeability, loaded / unloaded	% (°)	22 (12.4)	21 (11.9)	18 (10.2)
5.10	Service brake		Hydraulic	Hydraulic	Hydraulic
Motor					
6.1	Drive motor rating S2 60 min	kW	4.0×2	4.0×2	4.0×2
6.2	Pump motor rating at S3 - 15 %	kW	12.0	12.0	12.0
6.4	Battery voltage, nominal capacity K5	V/Ah	48 / 440	48 / 440	48 / 440
6.5	Battery weight	kg	820	1,000	1,000
6.7	Battery demension (L×W×H)	mm	978 / 545 / 635	978 / 630 / 635	978 / 630 / 635
Other Details					
8.1	Type of drive control		AC	AC	AC

Dimensions

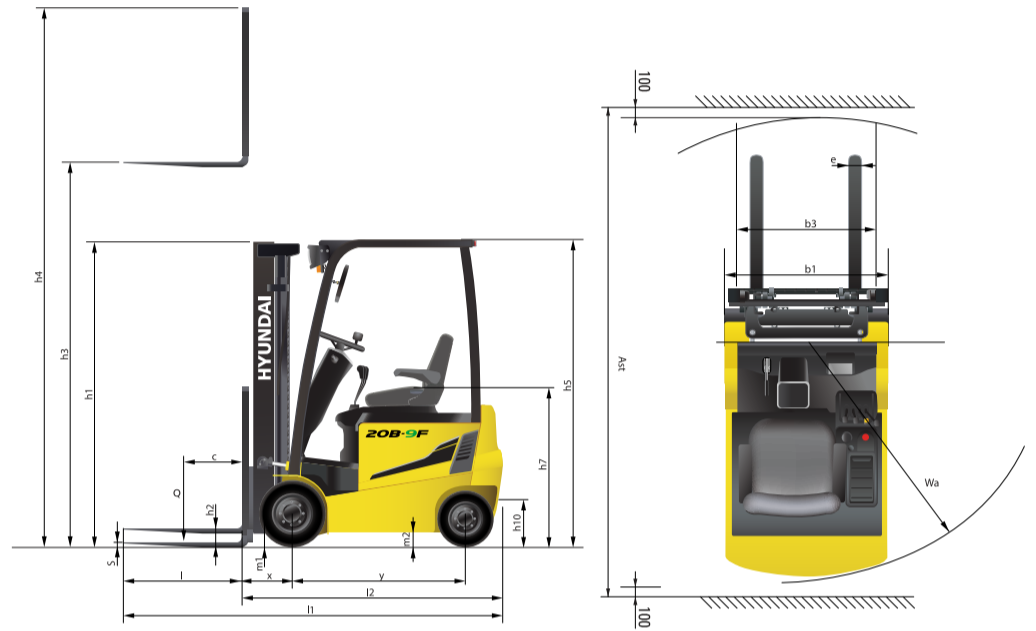

* Specifications in this catalog may vary depending on the options.

MEMO