

## Dimension

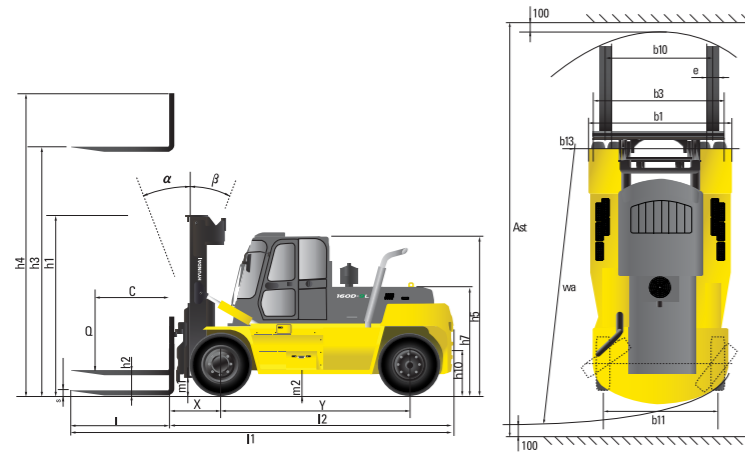

## Load Capacity

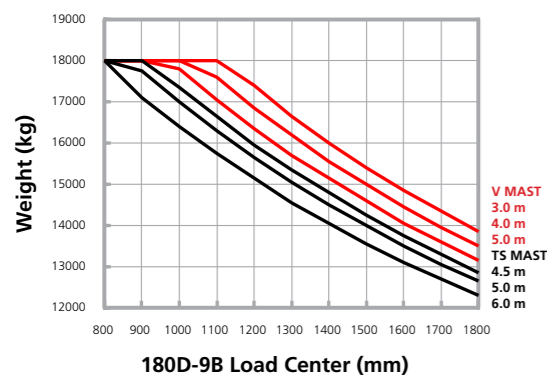
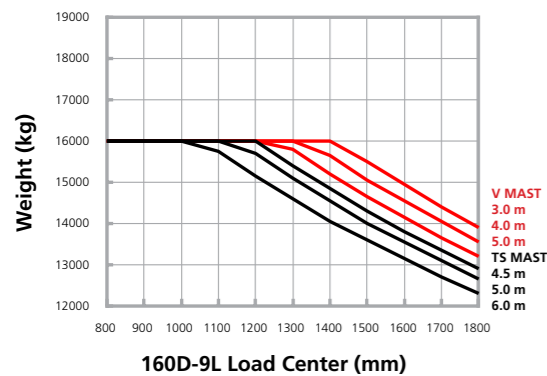

## Optional Items

- Fork (L) (mm) : 1800, 2000, 2450, 3150
- Mast : Simplex Mast / Triplex Mast
- MCV : 3-Spool / 4-Spool / 5-Spool, Finger tip
- Sliding Carriage
- Integral Side Shift + Fork Positioner
- Separator Holder Type Fork Carriage
- Air Compressor
- Seat : Heat, Leather
- Bluetooth Hands Free
- Beacon Lamp (LED)
- Air Conditioner & Heater
- Rear View Camera
- Weight Indicator
- Top Wiper
- RMS(Remote Management System)
- Rear Wheel Angle Monitoring
- Cabin
- Bias / Radial Tire

## Specification

Identification			
1.1	Manufacturer	Hyundai	Hyundai
1.2	Manufacturer's type designation	160D-9L	180D-9B
1.3	Drive : electric(battery or mains) , diesel, petrol ,fuel gas, manual	Diesel	Diesel
1.4	Type of operation : hand, pedestrian, standing, seated, order - picker	seated	seated
1.5	Load capacity / rated load	kg 16,000	18,000
1.6	Load center distance	c mm 1,200	900
1.8	Load distance, center of drive axle to fork	x mm 999	999
1.9	Wheelbase	y mm 3,750	3,750
Weights			
2.1	Service weight	kg 23,954	23,954
2.2	Axle loading, loaded front / rear	kg 37,448 / 2,506	39,181 / 2,773
2.3	Axle loading , unloaded front / rear	kg 12,065 / 11,888	12,065 / 11,888
Wheels, Chassis			
3.1	Tire	Pneumatic	Pneumatic
3.2	Tires size, front(∅ x width)	12.00-20-20PR	12.00-20-20PR
3.3	Tires size, rear(∅ x width)	12.00-20-20PR	12.00-20-20PR
3.5	Wheels, number front rear(x = driven wheels)	4 x 2	4 x 2
3.6	Track width, front	b10 mm 1,860	1,860
3.7	Track width, rear	b11 mm 2,034	2,034
Basic Dimensions			
4.1	Mast / fork carriage tilt forward / backward	degrees 10/10 (15/10)	10/10 (15/10)
4.2	Lowered mast height	h1 mm 3,200	3,200
4.3	Free lift height	h2 mm 0	0
4.4	Lift height	h3 mm 3,020	3,020
4.5	Extended mast height	h4 mm 4,660	4,660
4.7	Overhead guard (cab) height	h5 mm 3,075	3,075
4.8	Seat height / Standing height	h7 mm 1,910	1,910
4.12	Coupling height	h10 mm 610	610
4.19	Overall length	l1 mm 8,014	8,014
4.20	Length to face of forks	l2 mm 5,564	5,564
4.21	Overall width	b1 mm 2,540	2,540
4.22	Fork dimensions	s / e / l mm 100x250x2,450	100x250x2,450
4.24	Fork - carriage width	b3 mm 2,540	2,540
4.31	Ground clearance, loaded, under mast	m1 mm 245	245
4.32	Ground clearance, centre of wheelbase	m2 mm 380	380
4.33	Aisle width for pallets 1,000 x 1,200 crossways	Ast mm 8,902	8,902
4.34	Aisle width for pallets 800 x 1,200 lengthways	Ast mm 8,902	8,902
4.35	Turning radius	Wa mm 5,220	5,220
4.36	Smallest pivot point distance	b13 mm 2,048	2,048
Performance Data			
5.1	Travel speed, unloaded	km/h 35.2	35.2
5.2	Lift speed, loaded / unloaded	mm/s 330 / 450	290 / 450
5.3	Lowering speed, loaded / unloaded	mm/s 430 / 390	430 / 390
5.6	Drawbar pull, loaded	KN 134,518	131,477
5.7	Gradient performance, loaded	% 33	30.4
5.10	Service brake	Hydraulic	Hydraulic
Engine			
7.1	Engine manufacturer / Type	Cummins QS86.7	Cummins QS86.7
7.2	Engine power Acc. to Iso 1585	kW 122	122
7.3	Rated speed	1/min 2,300	2,300
7.4	No. Of cylinder / cubic capacity	/cm³ 6 / 6,690	6 / 6,690
7.5	Fuel consumption Acc. to VDI cycle	l/h 12.1	12.1
Other Details			
8.1	Type of drive control	Power Shift	Power Shift
8.2	Operating pressure for attachments(system/attach)	bar 230 / 165	230 / 165
8.3	Oil volume for attachments	l/min 203	203
8.4	Sound level at driver's ear according to DIN 12 053	dB 71.2	71.2

\* Standard and optional equipment may vary. Contact your Hyundai dealer for more information.  
 \* The machine may vary according to International standards.  
 \* The photos may include attachments and optional equipment that are not available in your area.

# 160D-9L / 180D-9B

Performance Enhanced For Tier-4 Final

MOVING YOU FURTHER

HYUNDAI CONSTRUCTION EQUIPMENT



**HYUNDAI**  
CONSTRUCTION EQUIPMENT

Head Office (Sales office)  
First tower, 55, Bundang-ro, Bundang-gu, Seongnam-si, Gyeonggi-do, Korea

PLEASE CONTACT

www.hyundai-ce.com

2018. 1 Rev. 3

**HYUNDAI**  
CONSTRUCTION EQUIPMENT

Some of the photos may include optional equipment.

# Your satisfaction is our priority!

Hyundai introduces a new line of 9-series diesel forklift trucks. The newly designed 4 wheel counterbalance trucks provide every operator comfortable driving, increased productivity and easy maintenance.

## New Diesel Forklift with Proven Quality and Advanced Technology

- Maximum Performance
- Spacious Operator's cab
- Weight Indicator (Optional)
- OPSS for Safe Operation
- Easy Serviceability
- Hi-MATE (Remote Management System) (Optional)
- 4.3Inch Color LCD (Centralized Information Display)
- FATC (Full Automatic Temperature Control) Airconditioner (Optional)



Some of the photos may include optional equipment.

# High Efficiency & Optimal Performance



Powerful engine and high technology systems provide you with enhanced performance and highest productivity.

**160D-9L**  
**180D-9B**



Some of the photos may include optional equipment.



### Full-automatic Transmission

Full-automatic transmission gives easy, convenient handling and soft, smooth shifting. The operator can select two kinds of automatic modes. (1st→3rd, 2nd→3rd)

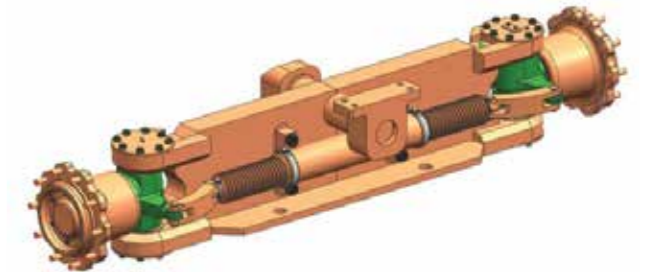

### Fully Hydrostatic Power Steering

The hydraulic steering system always guarantees smooth and flexible steering, preventing over-run and kick-back.

### Load Sensing System

Only flow required on cylinders is supplied. It makes energy saving. (No excessive flow)



### Durable drive axle

The hypoid type planetary reduction drive axle smoothly delivers desired torque to the drive wheels.



### Wet Disc Brake System

The wet disc brake system is virtually maintenance free and is enclosed to protect from dust and water.



## Cummins QSB6.7 Engine

122KW/2,300rpm

74.7kgf.m/1,500rpm

### Powerful Engine

The six cylinders turbo-charged engine is built for power, reliability and economy. This engine meets EPA Tier 4 Final and EU stage IV emission regulation.

### Excellent Fuel Efficiency

Fuel consumption rate is improved than previous model.

### DOC(Diesel Oxidation Catalyst)

### SCR(Selective Catalytic Reduction)

### EGR(Exhaust Gas Recirculation)

- High torque at low speeds
- Excellent transient behavior



### Increased Mast Tilting Angle

Utilizing the mast tilting angle of 15 degrees forward and 10 degrees backward, the operator can perform loading and unloading jobs safely and rapidly.



### Max.Gradeability (loaded)

Model	%
160D-9L / 180D-9B	33 / 30.4

### Max.Travel Speed (Unloaded)

Model	Km / h
160D-9L / 180D-9B	35.2

### Faster Travel Speed & Better Gradability

The powerful engine provides greater acceleration, better gradability and faster travel speed on any tough terrains or slopes.

# Best Convenience & Optimised Ergonomics



The ergonomically designed cabin provides full support and comfort to the operator.

**160D-9L**  
**180D-9B**



Some of the photos may include optional equipment.

## Spacious Operator Cabin

The newly designed cabin was conceived for more space, a wider field of view and operator comfort.

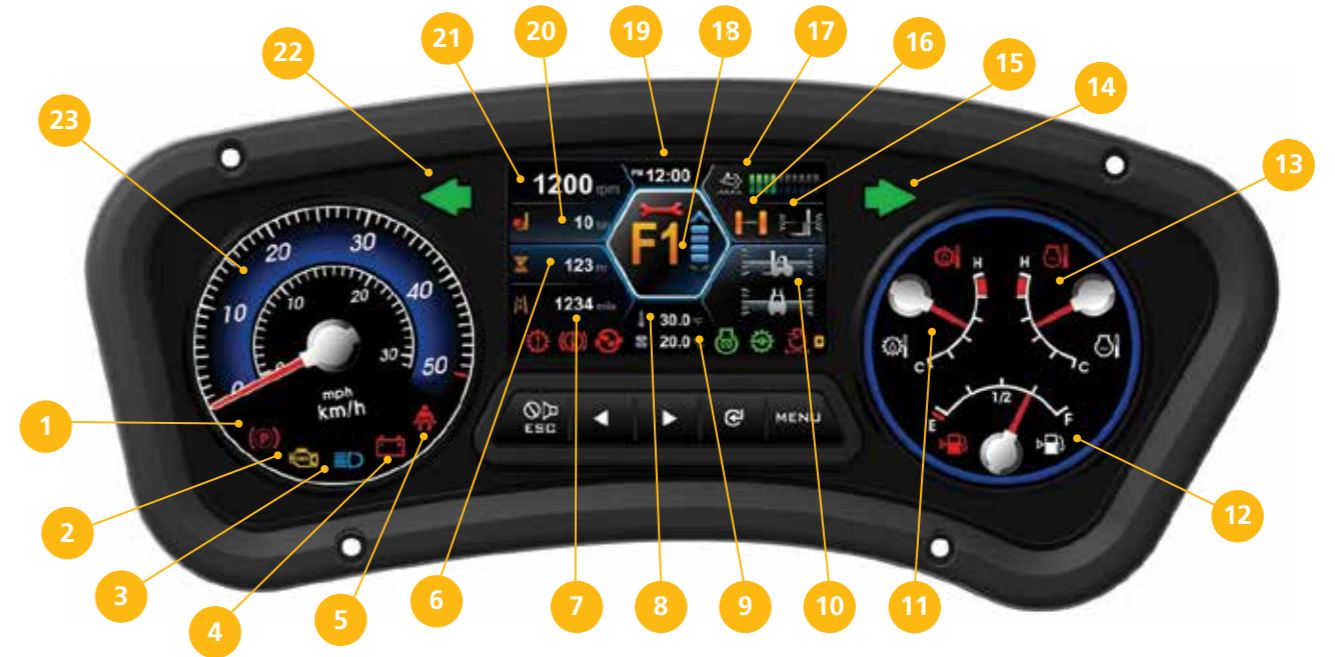

### New Design Cluster

1	Parking lamp	2	Engine check warning lamp	3	High beam indicator lamp
4	Operator presence indicator lamp	5	Seat belt warning lamp	6	Hour meter
7	Odometer	8	Outside temperature indicator	9	Air-con setting temp. indicator
10	Vehicle tilt angle indicator	11	Transmission oil temperature gauge	12	Fuel gauge
13	Engine coolant temperature gauge	14	Right turn signal indicator lamp	15	Mast tilt angle indicator
16	Rear wheel angle(option)	17	Urea level gauge	18	T/M information display
19	Clock	20	Load weight indicator(option)	21	Engine RPM indicator
22	Left turn signal indicator lamp	23	Speed gauge		



MP3 CD Player



Bluetooth Hands Free Remote Control Socket (Optional)



Centralized Instrument Switch Panel



### Luxury(Leather, Heat) Seat (Optional)

An attractive and adjustable seat, based on a human engineering design, provides great comfort, safety and durability.

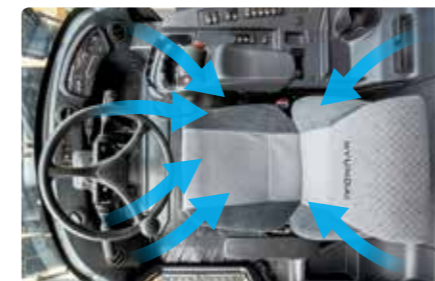

### High-output Air Conditioner & Heater (Optional)

Air Vent positions of the air conditioner with integrated the condenser is mounted on cabin front rear side to make a wide room in the cabin. And an air conditioner with high-output and heater always provide you with comfortable environment when you work. \*Especially Applied FATC(Full Automatic Temperature Control)



### Adjustable Steering Column

Steering handle is adjustable depending on the operator's body shape. Adjustability of steering column makes you more comfortable.



### Quick Response of Operating Control Levers

Only minimal operator's effort is required for precise, safe and productive control. (4 Lever : Standard), (3/5 Lever : Option)

# Advanced Safety



The safely designed driver's space makes your operating more comfortable.

**160D-9L**  
**180D-9B**



### Engine Control Mode

According to operating load, the operator can select engine mode by changing side panel switch.  
STD Mode : Fuel reduction mode for lightduty operating load  
POWER Mode : Heavy-duty or operating at slope



### Adjustable Engine Low Idle RPM

While engine runs, low idle rpm can be increased by unit of 25rpm and it keeps previously set rpm when engine restarts.

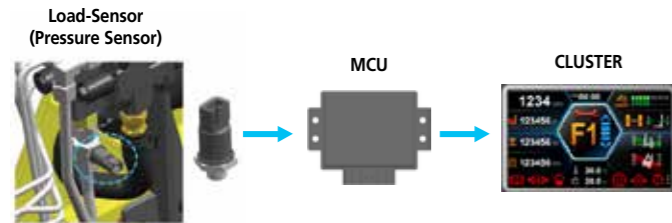

### Weight Indicator (Optional)

The optional Weight Indicator displays the load weight in the monitor. The load sensor reduces the time to check loaded weight and the alarm alerts the driver when overloaded.

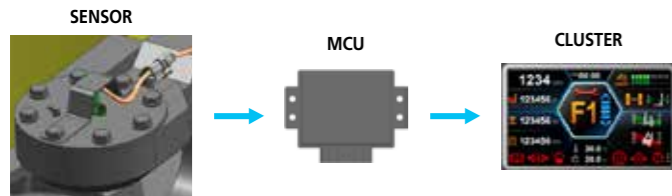

### Rear Wheel Angle Monitoring (Optional)

- indicate steering wheel angle for easy operation  
- Real-time steering wheel angle display



### Up-to-date Cooling System

The minimum fuel consumption and low noise are available by applying hydraulic cooling fan sensing intake air temperature, transmission oil temperature, coolant temperature and hydraulic temperature.



### Rear Tire Cover

The Rear tire cover with PE material is equipped to prevent clogging of the radiator from foreign substances.

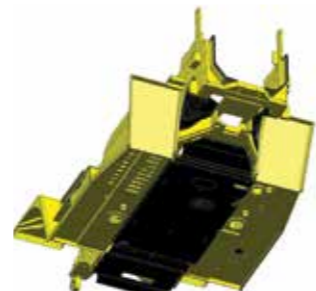

### Undercover (Optional)

The Under cover protect the engine and components from dusts caused by ground. It helps to lengthen Components life.



### OPSS (Operator Presence Sensing System)

When the operator is not in the seat all mast and drive movements are impossible.

Lift Lock   Tilt Lock   Drive Lock

Some of the photos may include optional equipment.



### Highly Durable Mast & Carriage Side Roller

Side roller with great durability for mast and carriage is included.



### Highly Durable Carriage

The carriage is very strong cause of applying the high tensile structural steel which has a excellent durability. Work at the narrow space is easy because the width of carriage is narrower than overall width of the vehicle.



### Excellent Night Work

- Various position of work lamp provides the operator more comfortable and safe operating environments.  
- Front : fender(2), mast(4)  
- Rear : cab(2)  
- LED Rear Combination Lamp

# Fast and Easy Maintenance

An ideal arrangement of components ensures easy access and convenience for maintenance.

**160D-9L**  
**180D-9B**



Some of the photos may include optional equipment.



**Cabin Tilting Automatic System**  
Cabin tilting automatic system makes servicing of all power train components quick and easy. An electrically assisted hydraulic actuated cylinder tilts operator cabin to left side about 53 degrees for easy access to inside of truck components.

## Large Engine Hood

Highly accessible engine compartment assures fast and efficient maintenance.

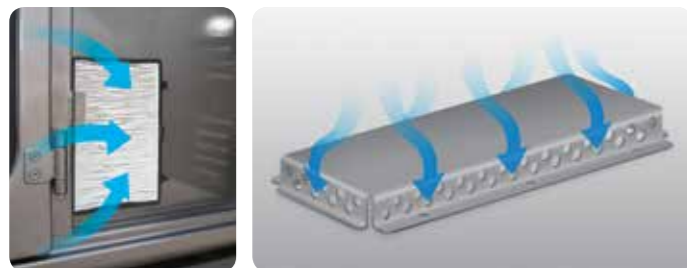

## Cabin Air Fresh Filter

The internal pressure is maintained to be slightly higher than that of outside to exclude dust and to reduce noise levels.



## Maintenance Management Display



## Engine Start Limit



## Integrated shaft type carriage

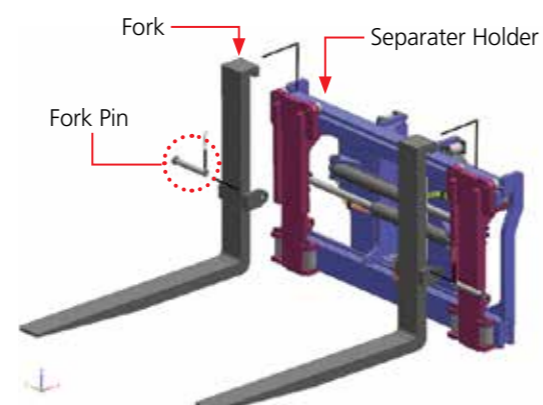

## Separator Holder Type Fork Carriage (Optional)

To improve handling and easily switch forks and other attachment Separator holder system is adopted as option. It is possible to install various attachments like coil ram easily.



\*Some of the photos may include optional equipment.



## Rear View Camera (Optional)

The rear view camera makes the operation more easy and convenient.



## Master Switch

A master switch disconnects the battery power to protect the electrical system from excess electrical drainage.



## Hi-MATE (Remote Management System)

Hi-MATE, Hyundai's proprietary remote management system, provides operators and dealer service personnel access to vital service and diagnostic information on the machine from any computer with internet access.

## Mast Specification

Mast Type	Overall Height (Lowered)		Maximum Fork Height		Free Lift Height		Tilt Angle		Load Capacity				Truck Weight (Unloaded)		
	in	mm	in	mm	in	mm	Fwd deg	Bwd deg	180D-9B		160D-9L		lb	kg	
									36 in LC lb	900 mm LC kg	48 in LC lb	1200mm LC kg			
2-STAGE LIMITED FREE LIFT	V300	126.0	3,200	118.9	3,020	0	0	10	10	40,000	18,000	36,000	16,000	52809	23,954
	V330	131.9	3,350	130.7	3,320	0	0	10	10	40,000	18,000	36,000	16,000	53037	24,058
	V350	135.8	3,450	138.6	3,520	0	0	10	10	40,000	18,000	36,000	16,000	53194	24,129
	V400	145.7	3,700	158.3	4,020	0	0	10	10	40,000	18,000	36,000	16,000	53672	24,346
	V450	155.5	3,950	178.0	4,520	0	0	10	10	40,000	18,000	36,000	16,000	54188	24,579
	V500	165.4	4,200	197.6	5,020	0	0	10	10	40,000	18,000	36,000	16,000	54599	24,766
	V550	175.2	4,450	217.3	5,520	0	0	10	10	40,000	18,000	35,200	16,000	55162	25,021
3-STAGE FULL FREE LIFT	V600	185.0	4,700	237.0	6,020	0	0	10	10	39,400	17,900	34,760	15,800	55573	25,207
	V650	194.9	4,950	256.7	6,520	0	0	10	10	38,800	17,600	34,210	15,550	55979	25,392
	V700	204.7	5,200	276.4	7,020	0	0	10	10	38,200	17,350	33,770	15,350	56390	25,578
	TS460	116.1	2,950	182.4	4,634	61	1,538	10	10	40,000	18,000	36,000	16,000	55213	25,044
	TS508	122.0	3,100	200.2	5,084	66	1,688	10	10	39,000	17,700	34,320	15,600	55644	25,240
	TS538	126.0	3,200	212.0	5,384	70	1,788	10	10	38,500	17,500	33,880	15,400	55896	25,354
	TS568	129.9	3,300	223.8	5,684	74	1,888	10	10	38,100	17,300	33,550	15,250	56146	25,468
	TS600	134.6	3,420	238.0	6,044	79	2,008	10	10	37,500	17,050	33,220	15,100	56388	25,578
	TS658	141.7	3,600	259.2	6,584	86	2,188	10	10	36,900	16,750	32,670	14,850	56792	25,761
	TS700	147.6	3,750	276.9	7,034	92	2,338	10	10	36,200	16,450	32,120	14,600	57335	26,007

\*: standard