

25/30/33L-9A 35LN-9A

LPG Counterbalance Trucks

MOVING YOU FURTHER

HYUNDAI CONSTRUCTION EQUIPMENT



■ Some of the photos may include optional equipment.

 **HYUNDAI**
CONSTRUCTION EQUIPMENT

PLEASE CONTACT

www.hyundai-ce.com

2018. 05 Rev. 3

 **HYUNDAI**
CONSTRUCTION EQUIPMENT

Your satisfaction is **our priority!**

Hyundai introduces a new line of 9-series LPG forklift trucks. The newly designed 4 wheel counterbalance trucks provide every operator comfortable driving, increased productivity and easy maintenance.

New Diesel Forklift with Proven Quality and Advanced Technology

- Maximum performance
- Spacious operator's cab
- Switch type parking brake
- 5.6 inch LCD color monitor
- Truck inclination warning system
- OPSS System for safe operation (Optional)
- Easy serviceability
- Max speed limit function
- HAC(Hillstart-Assistance Control)
- Password starting system
- Auto fork leveling system (Optional)
- Load weight indicator (Optional)



High Efficiency & Optimal Performance



Powerful engine and high technology systems provide you with enhanced performance and highest productivity.

25/30/33L-9A
35LN-9A



*Some of the photos may include optional equipment.



HMC L4KB(2.4L) Engine

60PS/2,300rpm

Powerful Engine - HMC L4KB(2.4L)

Market approved quality of HMC L4KB engine ensures incomparable performance, durability and additional value to the machine. Powerful and efficient engine provides excellent fuel consumption and excellent torque. (EPA/CARB Tier-IV Certified)

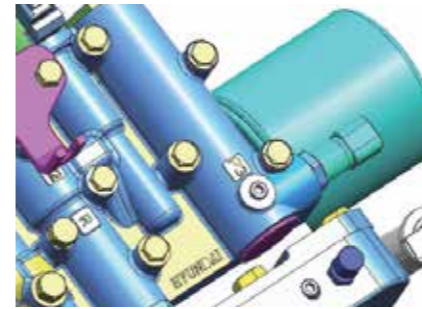

Clutch Protection System

The clutch protection system prevents excessive use of inching as well as minimizes change-impact.



Boosting Type Brake Valve (Optional)

The boosting type brake valve is applied for strong braking performance.



Highly Durable Drive Axle

The strengthened drive axle separable from transmission ensures low vibration and easy maintenance. The wet disc type brake is applied for easy operation, smooth response and maintenance free.



Fully Hydrostatic Power Steering

The hydraulic steering system always guarantees smooth and flexible steering, preventing over-run and kick-back.



Travel Speed (MAX)

Model	km / h
25L-9A	18.5
30L-9A	20.0
33L-9A	19.9
35LN-9A	18.9

Gradeability (MAX)

Model	%
25L-9A	40.7
30L-9A	31.9
33L-9A	28.3
35LN-9A	28.6

Faster Travel Speed & Gradeability

The powerful high-output engine provides greater acceleration, better gradeability and faster travel speed on any tough terrain or slope.

Best Convenience & Optimized Ergonomics



The ergonomically designed cabin and the new style LCD color monitor provides full support and comfort to the operator.

25/30/33L-9A
35LN-9A



*Some of the photos may include optional equipment.

Spacious Operator Cabin

The newly designed cabin provides wide visibility and spacious environment, ensuring all day comfort for the operator.



Optimized Pedal Position

On the 9-series the pedals are mounted to the console to reduce operator fatigue, and noise and dust from the engine compartment.



Adjustable Steering Wheel

To achieve a comfortable drive position, the angle of the steering column can easily be adjusted by a lever on the right-hand side of the steering column.



fingertip

Ergonomically designed fingertip control levers eliminates reaches and awkward shoulder. It gives operators comfortability and efficiency.



Comfortable Grammer Seat

Easily adjustable suspension seat, based on a human engineering design, reduces operator fatigue and provides greater comfort.

*ELR (Energy Locking Retractor) Type Seat Belt

*Heating and Head-rest (OPT)

Advanced LCD Monitor

The 5.6 inch wide screen LCD color monitor allows the operator to control the machine with ease. The monitor features speed, travel direction, battery discharge indicator and hour meter.



Travel Speed Control System (Option)

← In-Door : Max. Travel Speed (5~16 km/h)

← Out Door : Max Travel Speed (Max vehicle speed)

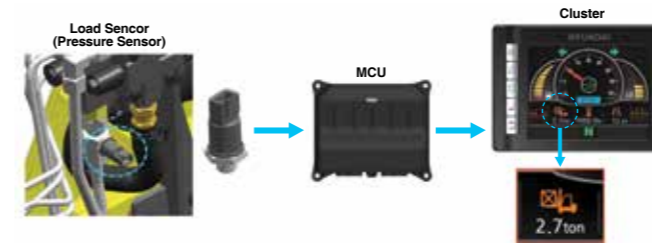

Load Indicator (Optional)

The optional load indicator displays the load weight on the monitor. The load sensor reduces the time to check loaded weight and the alarm alerts the driver when overloaded.



Auto Fork Leveling System (Optional)

To improve the productivity the auto fork leveling system will automatically stop the tilt movement when the mast is in a straight position.

Advanced Safety



The safely designed driver's space makes your operating more comfortable.

25/30/33L-9A
35LN-9A



Excellent Visibility for Safe Operation

Optimized lift cylinder arrangement provides operator with wider visibility. The panoramic mirror expands the driver's view when backing up.

*Some of the photos may include optional equipment.



HAC (Hill Start Assist Control System)

Anti-roll back the truck when the truck restart in the slope way.

Fork Safety Features

When the forks are being lowered, a down-control valve maintains the controlled speed. The down-safety valve prevents forks from dropping down in case of sudden damage of hydraulic line.

OPSS (Operator Presence Sensing System)

All mast and drive movements stop functioning when the operator is not in the seat.

Lift Lock Tilt Lock Drive Lock Parking



*Some of the photos may include optional equipment.



Strong Overhead Guard

Exceeding CEE and ANSI regulations, the overhead guard offers optimal protection combined with excellent all round visibility.



Low Entrance Height

The low entrance height ensures easy and safe access for the operator.



Steel Side Cover (Optional)

The strengthened steel side cover provides enhanced durability.



Rear Horn

Allowing operators hand to remain within forklift at all times for safety. An integral horn switch can prevent any hazardous situation at reverse mode.



Safety Lamps & Rear Reflectors

Halogen headlights and rear LED combination lights offer the driver visibility in all circumstances. Rear reflectors mounted on the counterweight enhance safety for the driver and the application. *Full LED lamp are available.(Optional)

Fast and Easy Maintenance

An ideal arrangement of components ensures easy access and convenience for maintenance.

25/30/33L-9A
35LN-9A



Large Engine Hood

Highly accessible engine compartment assures fast and efficient maintenance. The enlarged air cleaner(7") has extended service time of engine.

*Some of the photos may include optional equipment.



Waterproof & Dustproof Cover

Newly developed Waterproof and Dustproof fuse box and relay box for ease of maintenance.

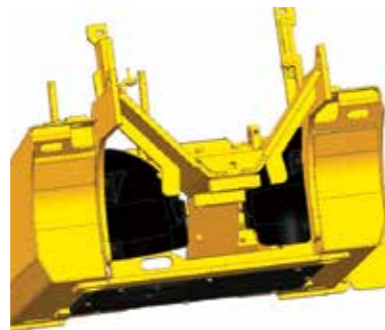

Rear Tire Cover (Optional)

The rear tire cover with PE material is well-suited to prevent clogging of the radiator from foreign substances.

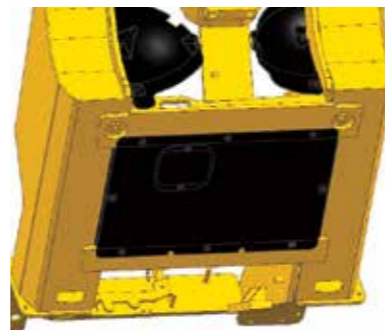

Under Cover (Optional)

The Under cover protect the engine and components from dusts caused by ground. It helps to lengthen Components life.



Rear View Camera
(Optional)



Parking Brake Switch
With auto parking function when the operator is not in the seat



Emergency Switch
(option)

*Some of the photos may include optional equipment.



Maintenance Management Display

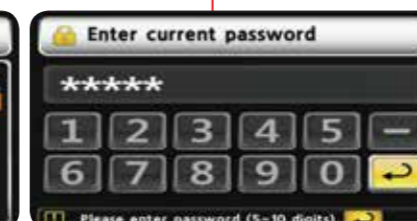

Password Starting System
(Anti-theft system)

New 9 Series

Dimension

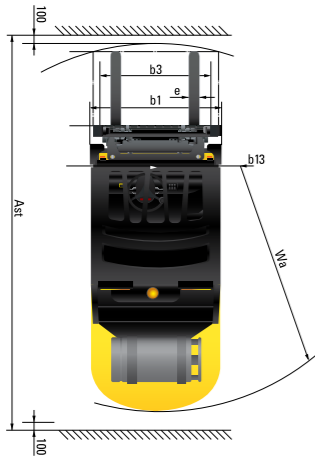
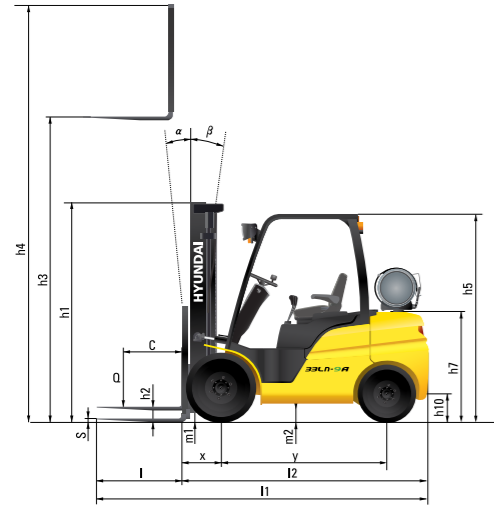

Specification

Identification						
1.1	Manufacturer	Hyundai	Hyundai	Hyundai	Hyundai	
1.2	Manufacturer's model designation	25L-9A	30L-9A	33L-9A	35LN-9A	
1.3	Drive: electric (battery or mains), diesel, petrol, fuel gas, manual	LPG	LPG	LPG	LPG	
1.4	Type of operation: hand, pedestrian, standing, seated, order-picker	seated	seated	seated	seated	
1.5	Load capacity / Rated load	kg 2500	3000	3300	3500	
1.6	Load center distance	c mm 500	500	500	500	
1.8	Load distance, center of drive axle to fork	x mm 468	468	468	468	
1.9	Wheelbase	y mm 1650	1700	1700	1700	
Weights						
2.1	Service weight	kg 3721	4116	4395	4535	
2.2	Axle loading, loaded front / rear	kg 5567 / 822	6375 / 906	6807 / 1054	6942 / 1092	
2.3	Axle loading, unloaded front / rear	kg 1600 / 2288	1667 / 2615	1628 / 2933	1449 / 3085	
Wheels, Chassis						
3.1	Tires ; Pneumatic(P), Solid(S), Non-marking(N)	P	P	P	P	
3.2	Tires size, front	Single	7.00-12-14PR	28X9-15-14PR	28X9-15-14PR	
		Double	6.00-15-10PR	6.00-10-10PR	6.00-10-10PR	
3.3	Tires size, rear	Single	6.50-10-14PR	6.50-10-14PR	6.50-10-14PR	
		Double	6.50-10-12PR	6.50-10-12PR	6.50-10-12PR	
3.4	Number of wheels front / rear (x=driven wheels)	2x / 2	2x / 2	2x / 2	2x / 2	
3.5	Tires width, front	Single	mm 999	1005	1005	1005
		Double	mm 1153	1153	1153	1153
	Tires width, rear	mm 980	980	980	980	
Basic Dimensions						
4.1	Mast / fork carriage tilt forward / backward (α / β)	degrees 6 / 10	6 / 10	6 / 10	6 / 10	
4.2	Lowered mast height	h1 (mm) 2175	2190	2260	2260	
4.3	Free lift	h2 (mm) 155	155	155	155	
4.4	Lift height	h3 (mm) 3305	3305	3305	3305	
4.5	Extended mast height	h4 (mm) 4485	4485	4485	4485	
4.7	Overhead guard height (cabin)	h5 (mm) 2160 (2170)	2180 (2190)	2180 (2190)	2180 (2190)	
4.8	Seat height / standing height rel. to SIP	h7 (mm) 1187	1212	1212	1212	
4.12	Coupling height	h10 (mm) 295	320	320	320	
4.19	Overall length	l1 (mm) 3657	3726	3782	3782	
4.20	Length to face of forks	l2 (mm) 2607	2676	2732	2757	
		Single	b1 (mm) 1200	1228	1228	1228
4.21	Overall width	Double	b1 (mm) 1517	1517	1517	1517
4.22	Fork dimensions(hook type)	l / e / s (mm) 1050 x 100 x 45	1050 x 122 x 45	1050 x 122 x 45	1050 x 122 x 45	
4.23	Fork carriage ISO 2328, class / type A,B	2A	3A	3A	3A	
4.24	Fork-carriage width	b3 (mm) 1102	1102	1102	1102	
4.31	Ground clearance, loaded, under mast	m1 (mm) 130	145	145	145	
4.32	Ground clearance, centre of wheelbase	m2 (mm) 157	181	181	171	
4.33	Aisle width for pallets 1,000x1,200 crossways (LxW)	Ast (mm) 4010	4081	4131	4131	
4.34	Aisle width for pallets 800x1,200 lengthways (WxL)	Ast (mm) 4210	4281	4331	4331	
4.35	Turning radius	Wa (mm) 2342	2413	2463	2490	
4.36	Smallest pivot point distance	b13 (mm) 714	731	731	731	
Performance Data						
5.1	Travel speed, unloaded	km/h 18.0	18.9	18.9	18.9	
5.2	Lift speed, loaded/ unloaded	mm/s 580 / 590	570 / 590	460 / 480	450 / 480	
5.3	Lowering speed, loaded/unloaded	mm/s 500 / 450	500 / 450	500 / 450	500 / 450	
5.5	Drawbar pull, loaded	kg 2686	2437	2443	2169	
5.7	Gradient performance, loaded	% 35.2	28.3	26.0	24.9	
5.9	Acceleration time, loaded/ unloaded(10m)	sec -	-	-	-	
5.10	Service brake	FOOT	FOOT	FOOT	FOOT	
Engine						
6.1	Engine manufacturer / type	HMC/L4KB	HMC/L4KB	HMC/L4KB	HMC/L4KB	
6.2	Engine power acc. to ISO 1585	kW/rpm 44.1 / 2300	44.1 / 2300	44.1 / 2300	44.1 / 2300	
6.3	Maximum Torque	kgf.m/rpm 19 / 1800	19 / 1800	19 / 1800	19 / 1800	
6.4	No. of cylinder / cubic capacity	EA/cc 4 / 2359	4 / 2359	4 / 2359	4 / 2359	
6.5	Fuel consumption acc. To VDI cycle	l/h -	-	-	-	
Other Details						
8.1	Type of drive control	PowerShift	PowerShift	PowerShift	PowerShift	
8.2	Operating pressure, system / attach	bar 196 / 162	206 / 162	206 / 162	216 / 162	
8.3	Oil volume (hydraulic)	l 30(60 Max.)	30(60 Max.)	30(60 Max.)	30(60 Max.)	
8.4	Sound pressure level (at driver's ear according to DIN 12053)	dB(A) 80	80	80	80	
8.5	Trailer coupling, type DIN	PIN	PIN	PIN	PIN	

25/30/33L-9A 35LN-9A

Load Capacity

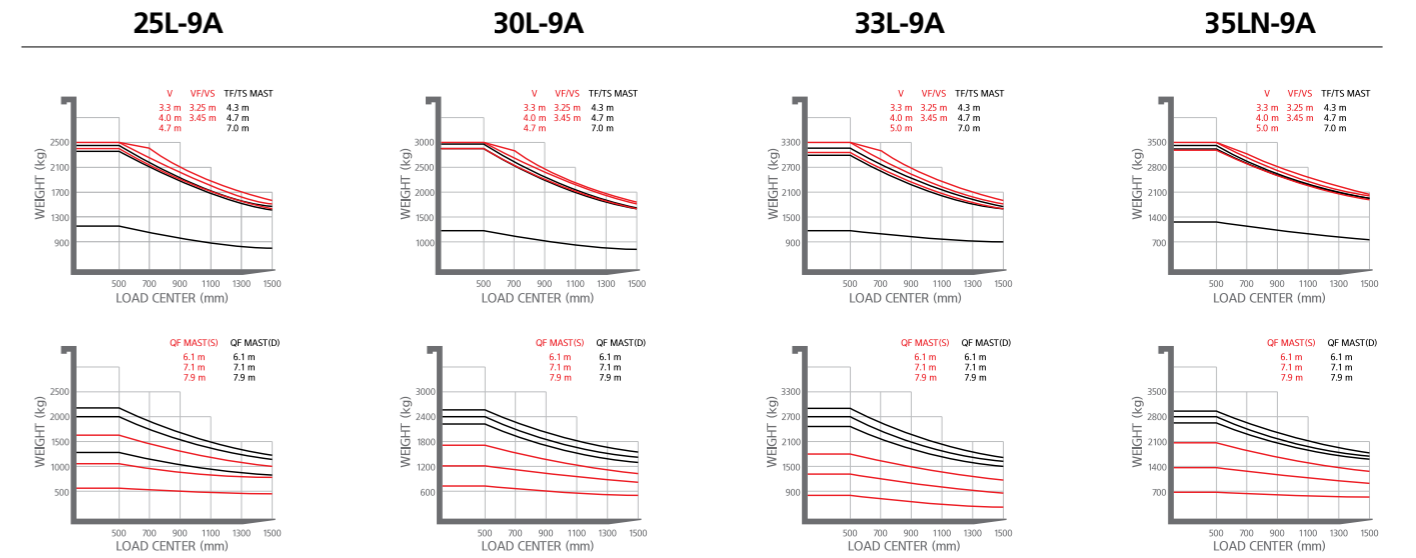

Various Attachments

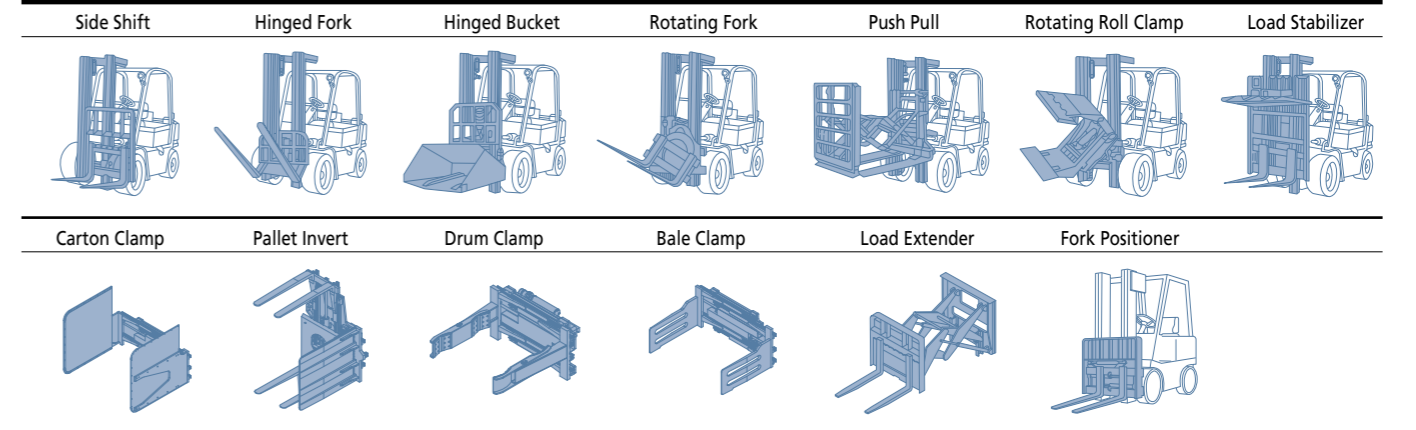

Optional Items

- Fork(mm)**
 25L-9A : 900, 1000, 1050(STD), 1200, 1350, 1500, 1650, 1800, 2100
 30/33L-9A, 35LN-9A : 900, 1050(STD), 1150, 1200, 1650, 1800, 1970, 2120, 2300, 2400
- Overshoe(mm)**
 25L-9A : 1300, 1500, 1700, 1800
 30/33L-9A, 35LN-9A : 1300, 1500, 1700, 1800
- Integral Sideshift, Fork Positioner, Sideshift, Integral Fork Positioner with Sideshift**
- Tire : Solid(superelastic) / Non-marking / Front double tire**
- M.C.V : 4-Spool**
- Seat : Armrest, Heat, Backrest Ext, Buckle SW**
- Load Weight Indicator**
- Auto Fork Leveling System**
- Rear View Camera**
- Cabin(Heater, A/C)**
- Hydraulic Pump Temperature / Pressure Indication**
- Battery Disconnect Switch(Master Switch)**
- Beacon Lamp(LED) (Amber, Red, Blue)**
- Rear work Lamp(Bulb or LED)**
- F-N-R & Horn Knob switch**
- Rear Horn with Handle**
- Finger Tip Control Lever**
- Full LED Lamp**