

35/40/45D-9K 50DA-9K

Diesel Counterbalance Trucks

MOVING YOU FURTHER

HYUNDAI CONSTRUCTION EQUIPMENT



 **HYUNDAI**
CONSTRUCTION EQUIPMENT

Head Office (Sales office)
First tower, 55, Bundang-ro, Bundang-gu, Seongnam-si, Gyeonggi-do, Korea

PLEASE CONTACT

www.hyundai-ce.com

2018. 03 Rev. 6

 **HYUNDAI**
CONSTRUCTION EQUIPMENT

Some of the photos may include optional equipment.

Your satisfaction is our priority!

Hyundai introduces a new life of **9series** diesel forklift truck.

The newly designed 4wheel counterbalances trucks provide every operator comfortable driving, increased productivity and easy maintenance.

New Diesel Forklift with Proven Quality and Advanced Technology

- Maximum performance
- Spacious operator's cab
- 5.6 inch LCD color monitor
- Truck inclination warning system
- weight indicator (optional)
- OPSS System for safe operation (optional)
- Easy serviceability



Some of the photos may include optional equipment.

High Efficiency & Optimal Performance



Powerful engine and high technology systems provide you with enhanced performance and highest productivity

35/40/45D-9K
50DA-9K



Some of the photos may include optional equipment.



Highly Durable Transmission

Powershift transmission of forward 2 stages and reverse 2 stages provides fast travel speed and quiet travel under any heavy load condition, and enhances work efficiency. The clutch protection system prevents excessive use of inching as well as minimizes change-impact.



Boosting type brake valve

The boosting type is applied for strong braking performance.



Highly Durable Drive Axle

The strengthened drive axle separable from transmission ensures low vibration and easy maintenance. The wet disc type brake is applied for easy operation, smooth response and maintenance free.



Integrated wheel rim

Integrated wheel rim provides significantly increased service life.



Fully hydrostatic power steering

A hydraulic steering system always guarantees smooth and flexible steering, preventing overrun and kick-back.

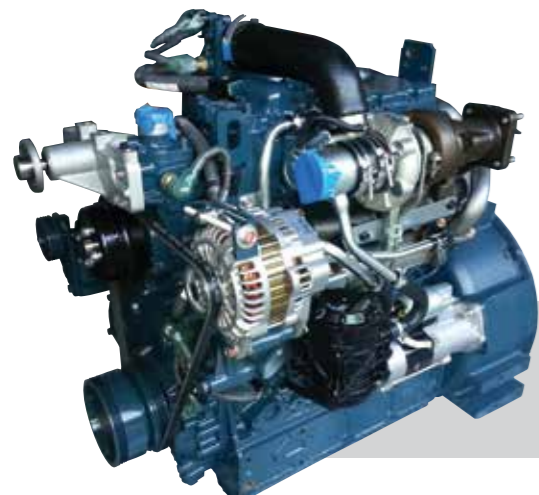

KUBOTA V3800-CR-T Engine

69.2KW / 2,200rpm

The common rail system has made it possible to optimize combustion and create more durable, quiet, and fuel-efficient engine. This engine meets EPA Tier-III and EU stage IIIA emission regulations.



Travel Speed (MAX)

Model	km / h
35D-9K	27.7
40D-9K	26.8
45D-9K	26.2
50DA-9K	26.7

Gradeability (MAX)

Model	% (degree)
35D-9K	48.2 (25.7)
40D-9K	42.7 (23.1)
45D-9K	38.8 (21.2)
50DA-9K	35.4 (19.5)

Faster Travel Speed and Gradeability

The powerful high-output engine provides greater acceleration, better gradeability and faster travel speed on any tough terrain or slope.

Best Convenience & Optimized Ergonomics



The ergonomically designed cabin and the new style LCD color monitor provide full support and comfort to the operator

35/40/45D-9K
50DA-9K



Some of the photos may include optional equipment.

Spacious Operator Cabin

The newly designed cabin provides wide visibility and spacious environment, ensuring all day comfort for the operator.



Optimized Pedal Position

The pedals are mounted to the console to reduce operator fatigue, and noise and dust from the engine compartment.



Adjustable Steering Wheel

To achieve a comfortable drive position, the angle of the steering column can easily be adjusted by a lever on the right-hand side of the steering column.



Grammer Seat (STD)

Easily adjustable suspension seat, based on a human engineering design, reduces operator fatigue and provides greater comfort.

- *ELR (Energy Locking Retractor) Type Seat Belt
- *Movable Armrest
- *Heating (OPT), Backrest Ext

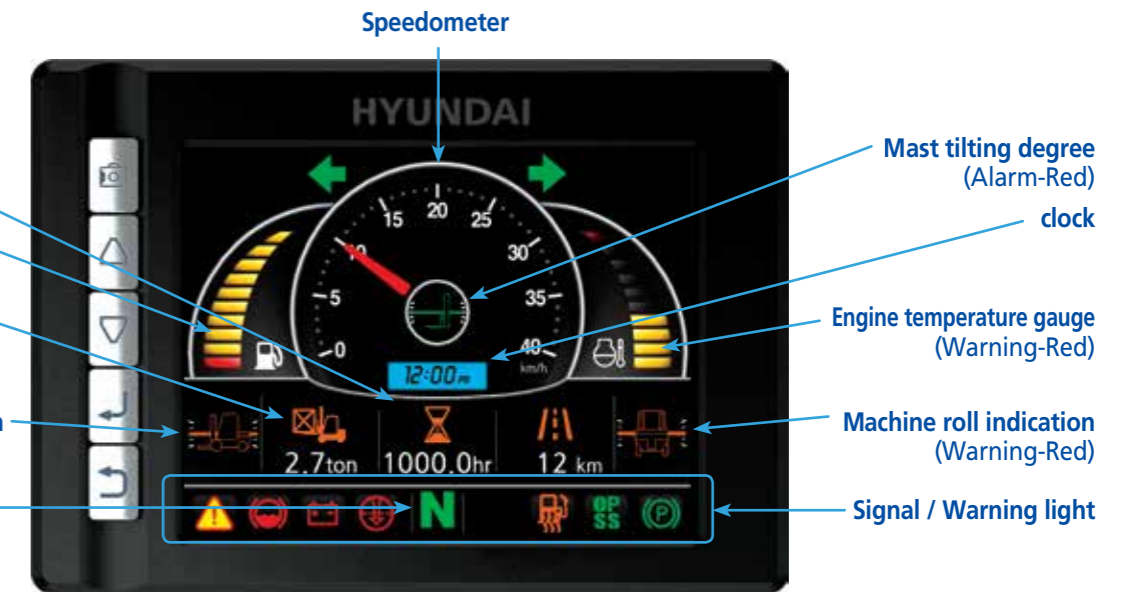

* Mast Tilting Degree is displayed when auto tilt leveling option is selected.

Advanced LCD Monitor

The 5.6 inch wide screen LCD color monitor allows the operator to control the machine with ease. The monitor features speed, travel direction, battery discharge indicator and hour meter. The operator can easily check the A/S information through Maintenance Management Display.



Automatic Gear Box

- The automatic gear box provides smooth and fast gear change ensuring maximum torque at any speed.
- 1) The second gear is selected when the travel speed reaches 5 km/h during acceleration.
 - 2) The first gear is selected when the travel speed is at 3 km/h during deceleration.



Truck Inclination Warning System

To improve the productivity and safety, the truck inclination warning system will monitor and indicate forward/backward, right / left degree of the forklift. The alarm alerts the operator when the forklift degree is over the ISO standard.

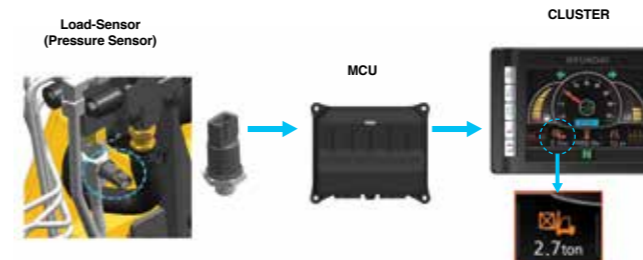

Weight indicator (Optional)

The optional load indicator displays the load weight in the monitor. The load sensor reduces the time to check loaded weight and the alarm alerts the driver when overloaded.

Advanced Safety



The safely designed driver's space makes your operating more comfortable.

35/40/45D-9K
50DA-9K



Excellent visibility for safe operation

Optimized lift cylinder arrangement provides operator with wider visibility. The panoramic mirror expands the driver's view when backing up.

Some of the photos may include optional equipment.



Strong overhead guard

The safety overhead guard exceeds EEC and ANSI regulations and protects the operator during hazardous jobs.



Large entrance step

Wide and non-slip step offers convenience and safety when entering and exiting truck.

Fork safety features

When the forks are being lowered, a down-control valve maintains the controlled speed. The down-safety valve prevents forks from dropping down in case of sudden damage of hydraulic line.

OPSS(Operator Presence Sensing System)

When the operator is not in the seat all mast and drive movements are impossible.

Lift Lock Tilt Lock Drive Lock



Some of the photos may include optional equipment.



Safety lamps & rear reflectors

LED combination lights and halogen headlights offer the driver visibility in all circumstances. Rear reflectors mounted on the counterweight enhance safety for the driver and the application.

Fast and Easy Maintenance

An ideal arrangement of components ensures easy access and convenience for maintenance

35/40/45D-9K
50DA-9K



Large Engine Hood

Highly accessible engine compartment assures fast and efficient maintenance. The enlarged air cleaner(8") extended service time of engine.

Some of the photos may include optional equipment.



Waterproof and Dustproof Cover

Newly developed Waterproof and Dustproof fuse box and relay box are mounted in one place for ease of maintenance.

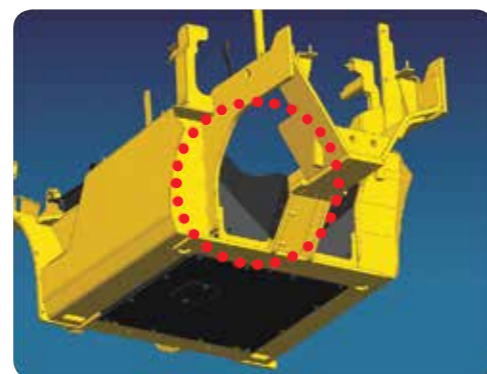

Rear Tire Cover/Under Cover (Optional)

The rear tire cover with PE material is well-suited to prevent clogging of the radiator from foreign substances. The Under cover protect the engine and components from dusts caused by ground. It helps to lengthen Components life.



• Rear view camera (Optional)

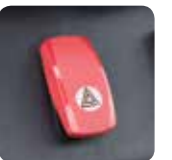

• Emergency switch (Optional)
• Rear work lamp (Optional)

Some of the photos may include optional equipment.



Maintenance Management display



Password starting system (Anti-theft system)



Key-locking fuel filler

New 9 Series

35/40/45D-9K 50DA-9K

Dimension

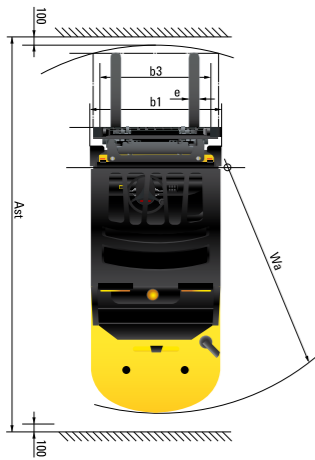
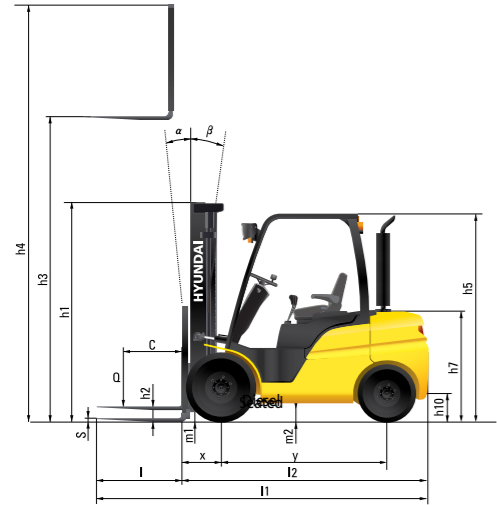

Specification

Identification		Hyundai	Hyundai	Hyundai	Hyundai
1.1	Manufacturer	Hyundai	Hyundai	Hyundai	Hyundai
1.2	Manufacturer's type designation	35D-9K	40D-9K	45D-9K	50DA-9K
1.3	Drive : electric (battery or mains), diesel, petrol, fuel gas, manual	Diesel	Diesel	Diesel	Diesel
1.4	Type of operation : hand, pedestrian, standing, seated, order-picker	Seated	Seated	Seated	Seated
1.5	Load capacity / rated load	kg 3,500	4,000	4,500	5,000
1.6	Load center distance	c mm 600	600	600	600
1.8	Load distance, center of front axle to fork	x mm 561	561	561	576
1.9	Wheelbase	y mm 2,000	2,000	2,000	2,000
Weights					
2.1	Service weight	kg 5,892	6,441	6,857	7,335
2.2	Axle loading, loaded front / rear	kg 8,220 / 1,172	9,136 / 1,305	9,922 / 1,435	10,780 / 1,555
2.3	Axle loading, unloaded front / rear	kg 2,814 / 3,627	2,814 / 3,627	2,810 / 4,047	2,813 / 4,522
Wheels, Chassis					
3.1	Tires : Pneumatic(P) / Solid(S) / Non-marking(N)	P	P	P	P
3.2	Tires size, front	8.25-15-14PR	7.50-16-12PR	7.50-16-12PR	7.50-16-12PR
3.3	Tires size, rear	7.00-12-12PR	7.00-12-12PR	7.00-12-14PR	7.00-12-14PR
3.5	Wheels, number front rear(x = driven wheels)	2 x 2	4 x 2	4 x 2	4 x 2
3.6	Track width, front	mm 1,132	1,282	1,282	1,282
3.7	Track width, rear	mm 1,140	1,140	1,140	1,140
Basic Dimensions					
4.1	Mast / fork carriage tilt forward / backward	degrees 8 / 10	8 / 10	8 / 10	8 / 10
4.2	Lowered mast height	h1 (mm) 2,235	2,220	2,220	2,220
4.3	Free lift height	h2 (mm) 120	120	120	120
4.4	Lift height	h3 (mm) 3,020	3,020	3,020	2,930
4.5	Extended mast height	h4 (mm) 4,234	4,234	4,234	4,147
4.7	Overhead guard (cab) height	h5 (mm) 2,220	2,210	2,210	2,210
4.8	Seat height / Standing height	h7 (mm) 1,070	1,070	1,070	1,070
4.12	Coupling height	h10 (mm) 364	364	364	364
4.19	Overall length	l1 (mm) 4,180	4,235	4,455	4,500
4.20	Length to face of forks	l2 (mm) 3,110	3,165	3,235	3,300
4.21	Overall width	b1 (mm) 1,370	1,740	1,740	1,740
4.22	Fork dimensions	l x e x s (mm) 1,070 x 122 x 50	1,220 x 150 x 50	1,220 x 150 x 50	1,200 x 150 x 60
4.23	Fork carriage ISO 2328, class / type A, B	III / A	III / A	IV / A	IV / A
4.24	Fork - carriage width	b3 (mm) 1,300	1,600	1,600	1,600
4.31	Ground clearance, loaded, under mast	m1 (mm) 170	155	155	155
4.32	Ground clearance, centre of wheelbase	m2 (mm) 215	205	205	200
4.33	Aisle width for pallets 1,000 x 1,200 crossways	Ast (mm) 4,629	4,676	4,726	4,771
4.34	Aisle width for pallets 800 x 1,200 lengthways	Ast (mm) 4,829	4,876	4,926	4,971
4.35	Turning radius	Wa (mm) 2,868	2,915	2,965	3,010
4.36	Smallest pivot point distance	1,009	1,009	1,009	1,009
Performance Data					
5.1	Travel speed, unloaded (1/2)	km/h 27.7	26.8	26.2	26.7
5.2	Lift speed, loaded / unloaded	mm/s 520 / 540	510 / 540	500 / 540	430 / 460
5.3	Lowering speed, loaded / unloaded	mm/s 500 / 500	500 / 500	500 / 500	500 / 500
5.5	Drawbar pull, loaded	kg 4,526	4,553	4,565	4,573
5.7	Gradient performance, loaded	% 48.2	42.7	38.8	35.4
5.9	Acceleration time, loaded / unloaded(10m)	sec -	-	-	-
5.10	Service brake	Hydraulic	Hydraulic	Hydraulic	Hydraulic
Engine					
6.1	Engine manufacturer / type	KUBOTA V3800-CR-T			
6.2	Engine power acc. to ISO 1585	kW/rpm 69.2 / 2,200	69.2 / 2,200	69.2 / 2,200	69.2 / 2,200
6.3	Maximum Torque	kgf.m/rpm 33.6 / 1,500	33.6 / 1,500	33.6 / 1,500	33.6 / 1,500
6.4	No. of cylinder / cubic capacity	anz/cm ³ 4 / 3,769	4 / 3,769	4 / 3,769	4 / 3,769
Other Details					
8.1	Type of drive control	Power shift 2/2	Power shift 2/2	Power shift 2/2	Power shift 2/2
8.2	Operating pressure (system / attach)	kgf/cm ² 210 / 150	210 / 150	210 / 150	210 / 150
8.3	Oil volume for attachments	ℓ / min 100	100	100	100

Load Capacity

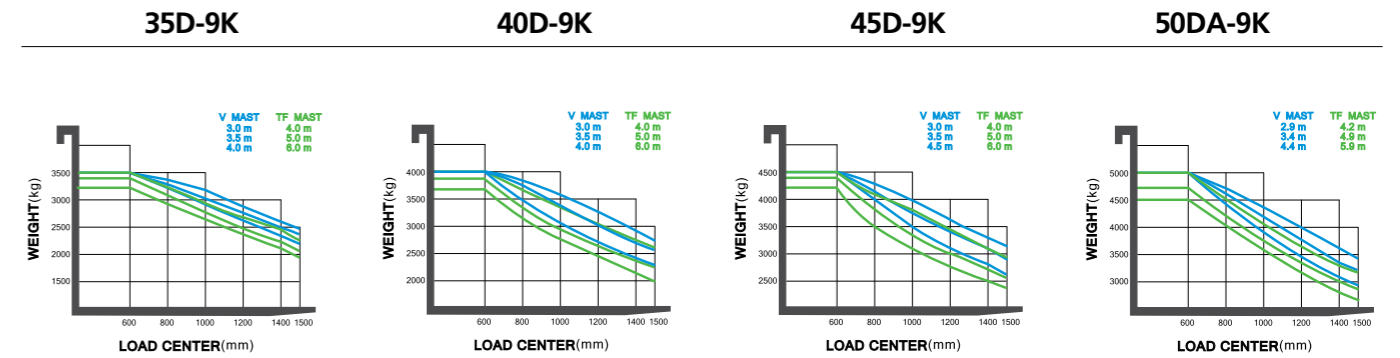

Various Attachments

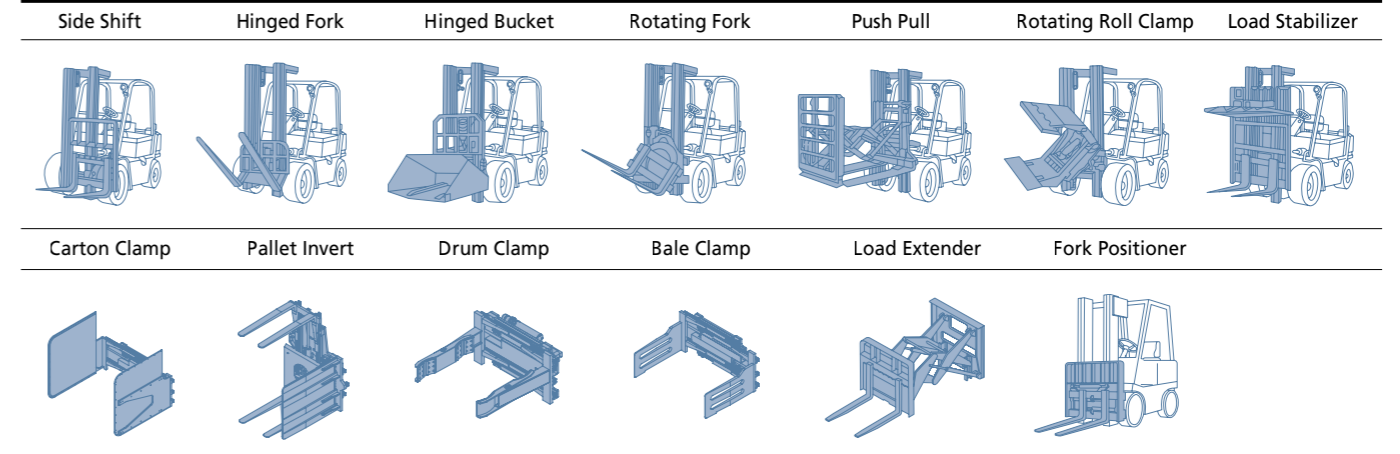

Optional Items

- **Fork(mm)**
35D-9K : 1220, 1370, 1520, 1670, 1820, 1970, 2120, 2400
40/45D-9K : 1070, 1370, 1520, 1670, 1820, 1970, 2200, 2400
50DA-9K : 1350, 1500, 1800, 2000, 2400
- **Overshoe(mm)**
1600, 1800, 2000, 2200
- **Integral Sideshift**
- **Tire : Pneumatic(STD) / Solid / Non-marking /**
Double Tire(Front tire) 35D-9K : 7.50-16-12PR
Single Tire(Front tire) 40D-9K/45D-9K/50DA-9K : 300-15-18PR
- **Seat : Arm rest, Back rest Ext, heat, seatbelt SW**
- **M.C.V : 2-Spool(STD), 3-Spool, 4-Spool, 5-Spool**
- **Weight Indicator**
- **Beacon Lamp (LED)**
- **Work Lamp**
- **OPSS : Travel, Travel + Mast**
- **Cabin (Heater & Air Conditioner)**
- **Rear View Camera**
- **High OHG (2,340mm)**
- **45D-9K : Class III Fork Carriage**