

Dimension

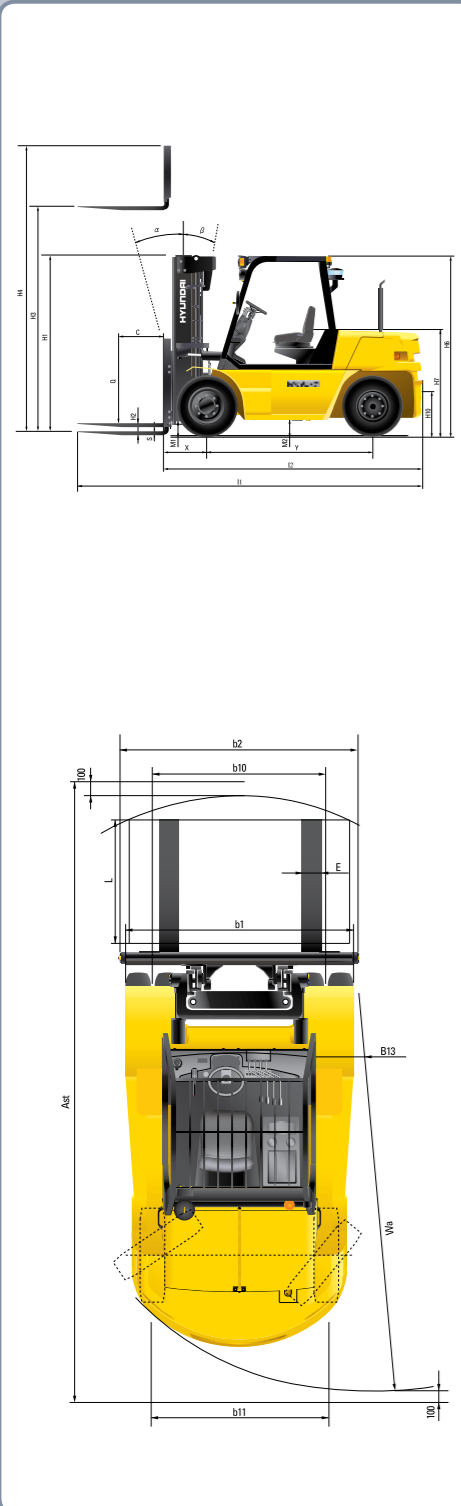

Specification

Identification				
1.1	Manufacturer	Hyundai	Hyundai	Hyundai
1.2	Manufacturer's type designation	50DF-7	60DF-7	70DF-7
1.3	Drive: electric (battery or mains), diesel, petrol, fuel gas, manual	DIESEL	DIESEL	DIESEL
1.4	Type of operation: hand, pedestrian, standing, seated, order-picker	seated	seated	seated
1.5	Load capacity / rated load	kg 5,000	6,000	7,000
1.6	Load center distance	c(mm) 600	600	600
1.8	Load distance, center of drive axle to fork	x(mm) 615	615	615
1.9	Wheelbase	y(mm) 2,300	2,300	2,300
Weights				
2.1	Service weight	kg 8,382	9,245	9,871
2.2	Axle loading, loaded front/rear	kg 12,027 / 1,356	13,573 / 1,673	14,964 / 1,907
2.3	Axle loading, unloaded front/rear	kg 4,385 / 3,997	4,403 / 4,842	4,260 / 5,604
Wheels, Chassis				
3.1	Tires: solid rubber, superelastic, pneumatic, polyurethane	pneumatic	pneumatic	pneumatic
3.2	Tire size, front (Φ x width)	8.25 - 15	8.25 - 15	8.25 - 15
3.3	Tire size, rear (Φ x width)	8.25 - 15	8.25 - 15	8.25 - 15
3.5	Wheels, number front x rear (x=driven wheels)	4 x 2	4 x 2	4 x 2
3.6	Track width, front	mm 1,578	1,578	1,578
3.7	Track width, rear	mm 1,602	1,602	1,602
Basic Dimensions				
4.1	Mast / fork carriage tilt forward / backward (α/β) degrees	15 / 10	15 / 10	15 / 10
4.2	Lowered mast height	h1 (mm) 2,515	2,515	2,515
4.3	Free lift	h2 (mm) 140	140	140
4.4	Lift height	h3 (mm) 3,030	3,030	3,030
4.5	Extended mast height	h4 (mm) 3,960	3,960	3,960
4.7	Overhead guard height	h5 (mm) 2,523	2,523	2,523
4.8	Seat height / standing height	h7 (mm) 1,464	1,464	1,464
4.12	Coupling height	h10 (mm) 385	385	385
4.19	Overall length	l1 (mm) 4,705	4,760	4,815
4.20	Length to face of forks	l2 (mm) 3,505	3,560	3,615
4.21	Overall width	b1 (mm) 2,068	2,068	2,068
4.22	Fork dimensions (hook type) s / e / l (mm)	60 x 150 x 1,200	65 x 150 x 1,200	65 x 150 x 1,200
4.23	Fork carriage ISO 2328, class / type A, B	Class IV	Class IV	Class IV
4.24	Fork-carriage width	b3 (mm) 2,087	2,087	2,087
4.31	Ground clearance, loaded, under mast	m1 (mm) 195	195	195
4.32	Ground clearance, centre of wheelbase	m2 (mm) 215	215	215
4.33	Aisle width for pallets 1,000x1,200 crossways (LxW)	Ast (mm) 5,164	5,211	5,257
4.34	Aisle width for pallets 800x1,200 lengthways (WxL)	Ast (mm) 5,364	5,411	5,457
4.35	Turning radius	Wa (mm) 3,349	3,396	3,442
4.36	Smallest pivot point distance	mm 1,224	1,224	1,224
Performance Data				
5.1	Travel speed, unloaded	km/h 22.8	22.7	22.7
5.2	Lift speed, loaded / unloaded	mm/s 440 / 460	430 / 460	420 / 460
5.3	Lowering speed, loaded / unloaded	mm/s 500 / 450	500 / 450	500 / 450
5.5	Drawbar pull, loaded	kg 6,660	6,687	6,720
5.7	Gradient performance, loaded / unloaded	% 50.3 / 28.7	43.1 / 26.1	38.5 / 23.6
5.9	Acceleration time, loaded / unloaded (10m)	-	-	-
5.10	Service brake	FOOT (Hydraulic)	FOOT (Hydraulic)	FOOT (Hydraulic)
Engine				
6.1	Engine manufacturer / type	HMC D4DD	HMC D4DD	HMC D4DD
6.2	Engine power acc. to ISO 1585	kW 73.6	73.6	73.6
6.3	Rated speed	1/min 2,300	2,300	2,300
6.4	No. of cylinder / cubic capacity	cm ³ 3,907	3,907	3,907
6.5	Fuel consumption acc. To VDI cycle	l/h 3.9	4.1	4.35
Other Details				
8.1	Type of drive control	Power shift	Power shift	Power shift
8.2	Operating pressure (system / attach)	bar 185 / 150	185 / 150	185 / 150
8.3	Oil volume (hydraulic)	l 105	105	105
8.4	Noise (at driver's ear according to DIN 12 053)	db(A) 84.1	84.1	84.1



■ Some of the photos may include optional equipment.

We build a better future

HYUNDAI DIESEL FORKLIFT TRUCKS Applied Tier 3 Engine

50DF/60DF/70DF-7

HYUNDAI FORKLIFT
HEAVY INDUSTRIES CO., LTD.

Head Office (Sales Office)
14TH FL., HYUNDAI BLDG. 140-2, KYE-DONG, JONGNO-GU, SEOUL, KOREA 110-793
TEL (82) (2) 746-4609, 4638 FAX (82) (2) 746-7444-7445

Americas Operation : Hyundai Construction Equipment Americas, Inc.
955 ESTES AVENUE, ELK GROVE VILLAGE, IL. 60007, U.S.A. TEL (1) 847-437-3333 FAX (1) 847-437-3574

Europe Operation : Hyundai Heavy Industries Europe N.V.
VOSSENDAAL 11, 2440 GEEL, BELGIUM TEL (32) 14-56-2200 FAX (32) 14-59-3405

PLEASE CONTACT

www.hyundai-ce.com

2011. 06. Rev 0

HYUNDAI
HEAVY INDUSTRIES CO., LTD.

50/60/70DF -7

New criterion of Forklift Trucks

Hyundai introduces a new line of diesel forklift trucks. Excellent power and performance make your business more profitable.



■ Some of the photos may include optional equipment.

High Power & Performance

Powerful Engine HMC D4DD Engine

Market approved quality of HMC D4DD engine ensures incomparable performance, durability and excellent fuel efficiency. This engine meets EPA Tier-III and EU stage IIIA emission regulations.



73.6kW/2,300rpm
38kgf.m/1,600rpm

State-of-the-art hydraulic system

The latest large-capacity hydraulic system reacts quickly during operation, and a low-noise control valve increases both efficiency and durability.

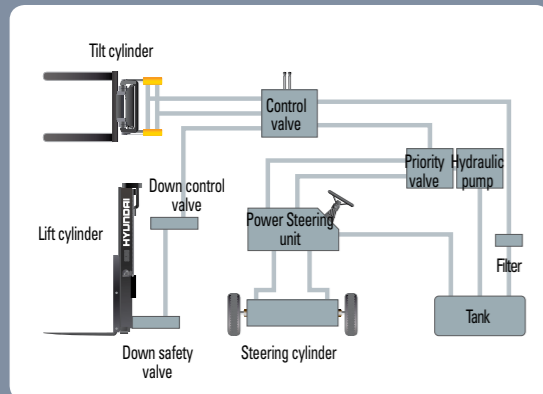

The new master on the job-site!

Smooth running, efficient and ergonomically designed, 50DF/60DF/70DF-7 series are made to meet your needs.



Some of the photos may include optional equipment.



Fast and stable performance

Being able to quickly raise and lower the mast, as well as tilt it forward and backward, providing the best operational conditions during unloading. When the truck is fully loaded, mast lowering speed is carefully controlled to ensure safety by the down control valve.

Faster travel speed & gradeability

The powerful high-output engine provides greater acceleration, better gradeability and faster travel speed on any tough terrain or slope.



Increased mast tilting angle

The mast tilting angle of 15 degrees forward and 10 degrees backward, the operator can safely and rapidly perform loading and unloading jobs.



Wet disc brake system

The wet disc brake system is virtually maintenance free and is enclosed to protect from dust and water.



Fully hydrostatic power steering

A hydraulic steering system always guarantees smooth and flexible steering, preventing overrun and kick-back.



OPSS (Operator Presence Sensing System)

Control of mast tilting, lifting and lowering is not possible through operation of the appropriate control when the operator is not in the normal position. (Option)

Comfortable Operation



Adjustable steering wheel

Steering wheel with horn button can be adjusted by a lever on the right-hand side for the most comfortable operator position.



Easy and safe shift lever

A single lever on the left side of the steering column gives the operator fast and easy controls of the direction.



Multi-function switch lever

Multi-functional switch lever gives easy access to lights and horn.



Quick response of operating control levers

Only minimal operator's effort is required for precise, safe and productive control.



Ergonomically designed with the operator in mind!

A design based on human engineering relieves fatigue and increases operator's efficiency.

■ Some of the photos may include optional equipment.



Ergonomically positioned pedals

Based on human engineering, the accelerator, brake and inching pedals are optimally positioned for convenience while operating the equipment.



Cup holder & console box

Additional storage spaces are located inside the operating space for operator's convenience.



New high visibility for safe operation

The operator is able to work with increased safety and accuracy due to a wider view mast.

Operator friendly gauges and water-resistant monitor panel



- | | |
|-------------------------------|---------------------------------|
| 1 Water temperature gauge | 8 T-mission oil temp warning |
| 2 Hour meter | 9 Battery charging warning lamp |
| 3 Turn lamp | 10 Air-cleaner warning |
| 4 Fuel gauge | 11 Head lamp |
| 5 Parking brake lamp | 12 Work lamp |
| 6 Fuel empty warning lamp | 13 Engine preheating |
| 7 Engine oil pressure warning | |

Easily adjustable suspension seat

An attractive and adjustable seat, based on a human engineering design, provides great comfort, safety and durability.



Full floating overhead guard mount

The anti-vibration rubber is installed between the guard and truck frame to reduce the source of vibration and noise while driving. This not only reduces operator's fatigue but also increases safety.



Endurance & Safety

Strong overhead guard

The safety overhead guard exceeds EEC and ANSI regulations and protects the operator during hazardous jobs.



Parking brake

Toggle type parking brake requires less efforts from the operator to set.



Ground clearance

The engine and transmission are assembled horizontally and positioned high in the frame to protect expansive components during operation on rugged surface.

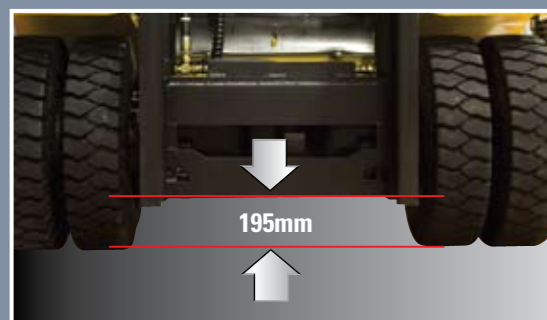

Highly durable split type drive axle

The durable drive axle provides fast travel speed and quiet travel under any heavy load condition, and boosts work efficiency.



Enhanced safety through high durability!

Safety and durability are priorities in the design of the equipment.



■ Some of the photos may include optional equipment.



Large footboard & hand grip

Wide "open" step offers convenience and safety when entering and exiting truck.

Heavy duty single unit frame

Heavy duty single unit type frame, designed on the basis of accurate structural analysis, guarantees durability and safety.



Easy access of electrical Components

Various electric parts are centralized in dash board resulting in improvement in maintenance.



Expansion bellows

The expansion bellows absorbs vibration and reduces noise generated from the exhaust gas system and also extends the life cycle of exhaust gas system.



Fuel tank safety valve

Integrated safety check valve shuts off fuel supply in the unlikely condition of a truck overturn.

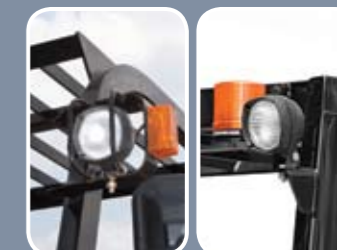

Bright, protected headlights and rear working light

Bright, protected headlights and rear working light are positioned for exceptional visibility.

Centralized design for easy service!

An ideal arrangement of component parts ensures easy accesses and conveniences for the maintenance.



Electrically monitored air filter

Air cleaner sensor alerts the operator of a restricted air filter and allows replacement before damage.



Visible pre-cleaner

Efficient, accessible pre-cleaner provides for longer engine life.



Brake fluid reservoir

Highly visible, easily accessible reservoir makes for quicker daily inspections.



An accessible, compact fuse box for easy inspection



Key-locking fuel cap with air vent



Automatic self locking gas spring

Engine compartment hood is held safely open by a self locking gas spring.



Large tool box

Additional tool box located in machine side for operator's convenience.



Easy change air cleaner

The air filter is readily accessible for cleaning or replacement.



Large open engine hood

Highly accessible engine compartment assures fast and efficient maintenance.



Engine oil condition check



Easy-to-access reservoir tank



Maintenance free battery



Easy-to-change radiator



Mechanic friendly fuel filter replacement

■ Some of the photos may include optional equipment.

Specification

Mast Specification

Model	Mast Type	Maximum Fork Height (mm)	Overall Height(mm)			Free Lift (mm)		Tilt Angle (deg)		Load Capacity without side shift at 600mm LC(kg)	Load Capacity with side shift at 600mm LC(kg)	Truck Weight (Unloaded)(kg)	
			Lowered	Extended		Without Load Backrest	With Std Load Backrest	Fwd	Bwd				
				W/o Load Backrest	W/Std Load Backrest								
50DF-7	2 Stage limited free lift	V270	2,730	2,365	3,691	4,020	140	140	15	10	5,000	5,000	8,555
		*V300	3,030	2,515	3,991	4,320	140	140	15	10	5,000	5,000	8,602
		V330	3,330	2,665	4,291	4,620	140	140	15	10	5,000	5,000	8,650
		V350	3,530	2,765	4,491	4,820	140	140	15	10	5,000	5,000	8,682
		V370	3,730	2,865	4,691	5,020	140	140	15	10	5,000	5,000	8,714
		V400	4,030	3,015	4,991	5,320	140	140	15	10	5,000	5,000	8,770
		V450	4,530	3,315	5,491	5,820	140	140	15	10	5,000	5,000	8,997
		V500	5,030	3,565	5,991	6,320	140	140	15	10	5,000	5,000	9,077
		V550	5,530	3,815	6,491	6,820	140	140	15	10	5,000	5,000	9,156
	V600	6,030	4,065	6,991	7,320	140	140	15	10	5,000	4,950	9,235	
	3 Stage full free lift	TF450/TS450	4,560	2,565	5,545	5,805	1,580	1,275	15	10	5,000	5,000	9,189
		TF500/TS500	5,060	2,765	6,045	6,305	1,780	1,475	15	10	5,000	5,000	9,281
		TF560/TS560	5,600	2,965	6,585	6,845	1,980	1,675	15	10	5,000	4,850	9,392
		TF600/TS600	6,060	3,165	7,045	7,305	2,180	1,875	15	10	5,000	4,700	9,479

Model	Mast Type	Maximum Fork Height (mm)	Overall Height(mm)			Free Lift (mm)		Tilt Angle (deg)		Load Capacity without side shift at 600mm LC(kg)	Load Capacity with side shift at 600mm LC(kg)	Truck Weight (Unloaded)(kg)	
			Lowered	Extended		Without Load Backrest	With Std Load Backrest	Fwd	Bwd				
				W/o Load Backrest	W/Std Load Backrest								
60DF-7	2 Stage limited free lift	V270	2,730	2,365	3,911	4,020	140	140	15	10	6,000	6,000	9,197
		*V300	3,030	2,515	4,211	4,320	140	140	15	10	6,000	6,000	9,245
		V330	3,330	2,665	4,511	4,620	140	140	15	10	6,000	6,000	9,292
		V350	3,530	2,765	4,711	4,820	140	140	15	10	6,000	6,000	9,324
		V370	3,730	2,865	4,911	5,020	140	140	15	10	6,000	6,000	9,356
		V400	4,030	3,015	5,211	5,320	140	140	15	10	6,000	6,000	9,412
		V450	4,530	3,315	5,711	5,820	140	140	15	10	6,000	6,000	9,640
		V500	5,030	3,565	6,211	6,320	140	140	15	10	6,000	5,950	9,719
		V550	5,530	3,815	6,711	6,820	140	140	15	10	6,000	5,750	9,799
	V600	6,030	4,065	7,211	7,320	140	140	15	10	6,000	5,600	9,877	
	3 Stage full free lift	TF450/TS450	4,560	2,565	5,765	5,805	1,360	1,275	15	10	6,000	5,850	9,848
		TF500/TS500	5,060	2,765	6,265	6,305	1,560	1,475	15	10	6,000	5,650	9,940
		TF560/TS560	5,600	2,965	6,805	6,845	1,760	1,675	15	10	5,950	5,500	10,051
		TF600/TS600	6,060	3,165	7,265	7,305	1,960	1,875	15	10	5,800	5,350	10,139

Model	Mast Type	Maximum Fork Height (mm)	Overall Height(mm)			Free Lift (mm)		Tilt Angle (deg)		Load Capacity without side shift at 600mm LC(kg)	Load Capacity with side shift at 600mm LC(kg)	Truck Weight (Unloaded)(kg)	
			Lowered	Extended		Without Load Backrest	With Std Load Backrest	Fwd	Bwd				
				W/o Load Backrest	W/Std Load Backrest								
70DF-7	2 Stage limited free lift	V270	2,730	2,365	3,911	4,020	140	140	15	10	7,000	7,000	9,823
		*V300	3,030	2,515	4,211	4,320	140	140	15	10	7,000	7,000	9,871
		V330	3,330	2,665	4,511	4,620	140	140	15	10	7,000	7,000	9,918
		V350	3,530	2,765	4,711	4,820	140	140	15	10	7,000	7,000	9,950
		V370	3,730	2,865	4,911	5,020	140	140	15	10	7,000	7,000	9,982
		V400	4,030	3,015	5,211	5,320	140	140	15	10	7,000	7,000	10,038
		V450	4,530	3,315	5,711	5,820	140	140	15	10	7,000	7,000	10,266
		V500	5,030	3,565	6,211	6,320	140	140	15	10	7,000	6,850	10,345
		V550	5,530	3,815	6,711	6,820	140	140	15	10	7,000	6,650	10,425
	V600	6,030	4,065	7,211	7,320	140	140	15	10	7,000	6,500	10,503	
	3 Stage full free lift	TF450/TS450	4,560	2,565	5,765	5,805	1,360	1,275	15	10	7,000	6,750	10,474
		TF500/TS500	5,060	2,765	6,265	6,305	1,560	1,475	15	10	7,000	6,600	10,566
		TF560/TS560	5,600	2,965	6,805	6,845	1,760	1,675	15	10	6,900	6,400	10,677
		TF600/TS600	6,060	3,165	7,265	7,305	1,960	1,875	15	10	6,700	6,200	10,765

*Standard

Load Capacity

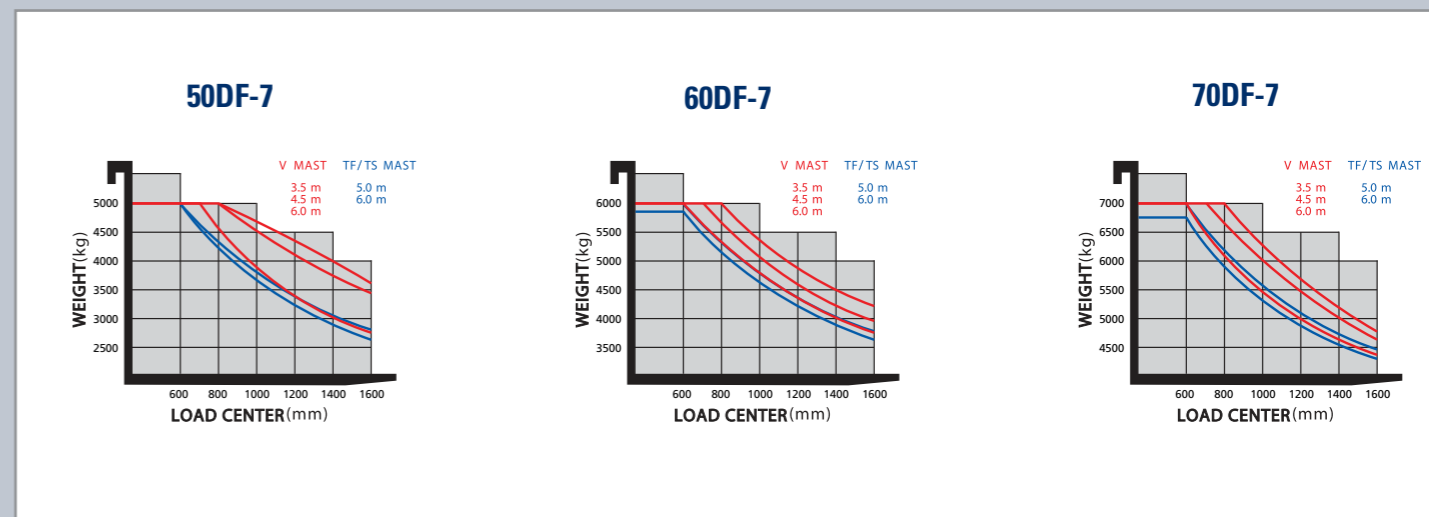

Various Attachments

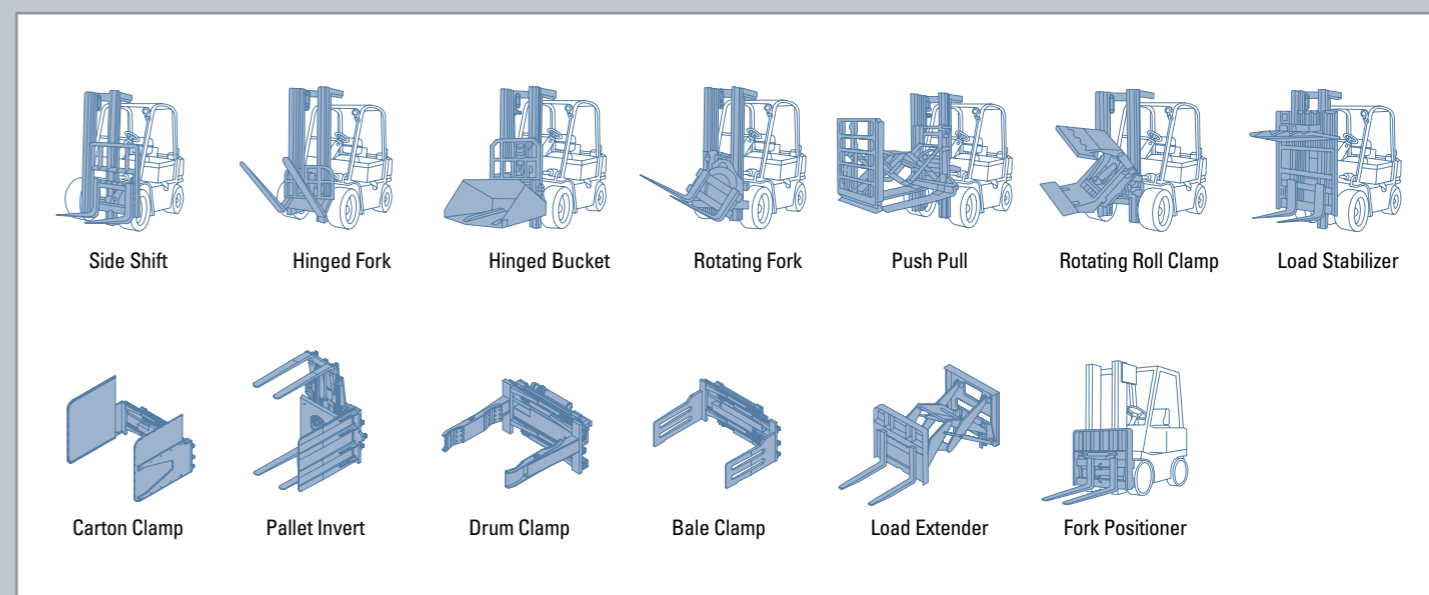

Optional Items

- **FORK (LxWxT)(mm)**
50DF-7
· 1,350 X 150 X 60 · 1,500 X 150 X 60 · 1,800 X 150 X 60
· 2,000 X 150 X 60 · 2,400 X 150 X 60
60/70DF-7
· 1,350 X 150 X 65 · 1,500 X 150 X 65 · 1,800 X 150 X 65
· 2,000 X 150 X 65 · 2,400 X 150 X 65
- **OVER SHOE**
1,800 / 2,000 / 2,200 / 2,300
- **SOLID NON-MARKING**
- **SEAT** : SEAT BELT, ARM REST, HIP REST
- **INTERNAL PIPING**
- **CABIN & HEATER**
CABIN, AIRCON, HEATER
- **MUFFLER** : HORIZONTAL
- **MASTER SWITCH**
- **ELE.BEACON**
- **HAZARD SWITCH**
- **MCV** : 3-SPOOL / 4-SPOOL / 5-SPOOL