

# 80D-9

With Tier4 Final Engine installed

MOVING YOU FURTHER

HYUNDAI MATERIAL HANDLING



PLEASE CONTACT

[www.hyundai-ce.com](http://www.hyundai-ce.com)

2018. 07. Rev. 4



Some of the photos may include optional equipment.

# Your Satisfaction is Our Priority!

Hyundai introduces a new line of 9-series 8 ton diesel forklift trucks. The newly designed 4 wheel counterbalance trucks provide every operator comfortable driving, increased productivity and easy maintenance.

## New Diesel Forklift with Proven Quality and Advanced Technology

- Maximum performance
- Spacious operator's cab
- Load indicator
- OPSS(Operator Presence Sensing System) for safe operation
- Easy serviceability
- Hi-mate (Remote Management System)



Some of the photos may include optional equipment.

# High Efficiency & Optimal Performance

Powerful engine and high technology systems provide you with enhanced performance and highest productivity.

**80D-9**



Some of the photos may include optional equipment.



### Full-Automatic Transmission

Full-automatic transmission gives easy, convenient handling and soft, smooth shifting. The operator can select two kinds of automatic mode.



### Fully Hydrostatic Power Steering

The hydraulic steering system always guarantees smooth and flexible steering, preventing over-run and kick-back.



### Highly Durable Split Type Drive Axle

The durable drive axle provides fast travel speed and quiet travel under any heavy load condition, and boosts work efficiency.



### Wet Disc Brake System

The wet disc brake system is virtually maintenance free and is enclosed to protect from dust and water.



## Cummins QSF3.8 Engine

75KW/2,200rpm

42.3kgf·m/1,600rpm

### Powerful Engine

The 4 cylinders turbo-charged engine is built for power, reliability and economy. This engine meets EPA, CARB Tier-4 Final and EU stage IV emission regulation.

### High Pressure Common Rail Fuel System(HPCR)

Upgraded HPCR System provides excellent start

### Ability & Emission Control

- Combustion efficiency enhancement
- Low noise, Low vibration

### Selective Catalytic Reduction(SCR)

- Reduces NOx emissions to near-zero level
- NO DPF



### Increased Mast Tilting Angle

Utilizing the mast tilting angle of 15 degrees forward and 10 degrees backward, the operator can perform loading and unloading jobs safely and rapidly. (Optional angles are available; 15/6degree & 6/6degree)



### Max.Gradeability (loaded/Unloaded)

Model	%
80D-9	35.2 / 26.5

### Max.Travel Speed (Unloaded)

Model	Km / h
80D-9	35

### Faster Travel Speed & Better Gradability

The powerful engine provides greater acceleration, better gradability and faster travel speed on any tough terrains or slopes.

# Best Convenience & Optimised Ergonomics

The ergonomically designed cabin provides full support and comfort to the operator.

**80D-9**



## Spacious Operator Cabin

The newly designed cabin was conceived for more space, a wider field of view and operator comfort.

Some of the photos may include optional equipment.



## Centralized Instrument Switch Panel



## Grammer Seat (STD)

An attractive and adjustable seat, based on a human engineering design, provides great comfort. And the angle of the armrest can be adjusted to reduce the fatigue of the driver.

- Applied the weight of the driver(45~170kg)
- ELR type seat belt standard
- Heater and Head Rest (Option)



## MP3 CD Player



## Quick Response of Operating Control Levers

Only minimal operator's effort is required for precise, safe and productive control.



## Ergonomically Positioned Pedals

Based on human engineering the accelerator, brake and inching pedals are optimally positioned for the operator's convenience.



## Adjustable Steering Wheel

Steering wheel with horn button can be adjusted by a lever on the right-hand side for the most comfortable operator position.



## High-Output Air Conditioner & Heater

An air conditioner with integrated the condenser is mounted on upper side of the cabin to make a wide room in the cabin. And an air conditioner with high-output and heater always provide you with comfortable environment when you work.

# Advanced Safety

The safely designed driver's space makes your operating more comfortable.

**80D-9**



### Direct Flow Air Cleaner

Cummins air cleaner introduced to enhance the performance of Tier-4 engines. More compact and efficient than previous cylindrical style air cleaners. Simple filter element change with capability to extend intervals



### Electrically Monitored Air Filter

Air cleaner sensor alerts the operator of a clogged air filter and allows replacement before damage.



### Exterior

A strong overhead guard, which meets ISO 6055 regulation, protects the operator in hazardous jobs.

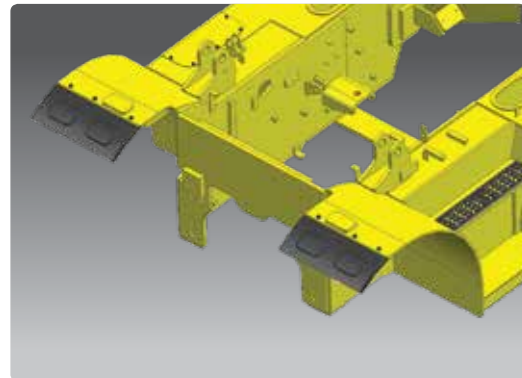

### Front Mudguard STD.

Front mud guard protect the equipment from foreign substances caused by the front tires. It helps to use the equipment clearly.



### Cabin Tilting Automatic System

Cabin tilting automatic system makes servicing of all power train components quick and easy. An electrically assisted hydraulic actuated cylinder tilts operator cabin to right side about 42.5 degrees for easy access to inside of truck components.

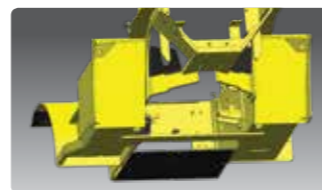

### Under Cover (Option)

The Under cover protect the engine and components from dusts caused by ground. It helps to lengthen components life.

### OPSS (Operator Presence Sensing System)

When the operator is not in the seat all mast and drive movements are impossible. (option)

Lift Lock Tilt Lock Drive Lock



Some of the photos may include optional equipment.

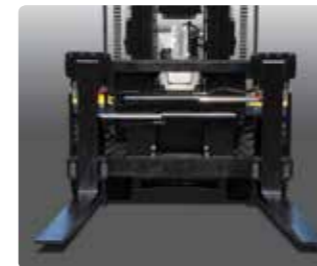

### Highly Durable Carriage

The carriage is very strong cause of applying the high tensile structural steel which has a excellent durability.



### Large Footboard & Handle

Wide "open" step offers convenience and safety when entering and exiting the truck.

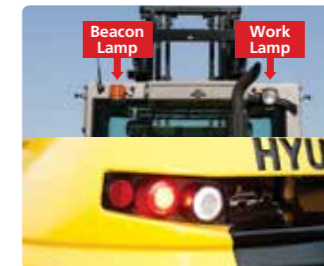

### Excellent Lights

- Various position of work lamp provides the operator more comfortable and safe operating environments.
- On Cabin:
  - 2 Front head lamps
  - 1 Rear work lamp
  - 1 beacon lamp (optional)
- LED Rear Combination lamps



### Bright, Protected Head Lights

# Fast and Easy Maintenance

An ideal arrangement of components ensures easy access and convenience for maintenance.

**80D-9**



## Tilting Cabin & Large Engine Hood

Highly accessible engine compartment assures fast and efficient maintenance.

Some of the photos may include optional equipment.



Grease Inlet



Maintenance Free Battery



## Rear View Camera (Option)

The rear view camera makes the operation more easy and convenient. And the monitor supports 4 camera channels.



Pre-Cleaner



Fuel Cap



Some of the photos may include optional equipment.



## Easy Change Air Cleaner

This air filter is readily accessible for cleaning or replacement.



## Cabin Air Fresh Filter

The internal pressure is maintained to be slightly higher than that of outside to exclude dust and to reduce noise levels.



## Master Switch

A master switch disconnects the battery power to protect the electrical system from excess electrical drainage. (optional)



## Maintenance Management Display



## Engine Start Limit

## Mast Specification (Hook/Shaft Type)

Standard : Hook-On Type Fork & Carriage

Model	Mast Type	Maximum Fork height		Overall Height								Free Lift				Tilt Angle TRUCK		Load capacity w/o side shift At 24 in (600mm)LC		Load capacity w/integral side shift At 24 in (600mm)LC		TRUCK WEIGHT UNLOADED	
				Low ered				Extended				Without Load Backrest		With Std Load Backrest		Fwd deg	Bwd deg	lb	kg	lb	kg	lb	kg
				in	mm	in	mm	in	mm	in	mm	in	mm	in	mm								
80D-9	2-STAGE LIMITED FREE LIFT	V270	107.9	2740	99.4	2525	159.4	4048	159.4	4050	5.9	150	5.9	150	15	10	17500	8000	17500	8000	25487	11559	
		V300	119.7	3040	105.3	2675	171.2	4348	171.3	4350	5.9	150	5.9	150	15	10	17500	8000	17500	8000	25595	11608	
		V330	131.5	3340	111.2	2825	183.0	4648	183.1	4650	5.9	150	5.9	150	15	10	17500	8000	17500	8000	25703	11657	
		V350	139.4	3540	115.2	2925	190.9	4848	190.9	4850	5.9	150	5.9	150	15	10	17500	8000	17500	8000	25776	11690	
		V370	147.2	3740	119.1	3025	198.7	5048	198.8	5050	5.9	150	5.9	150	15	10	17500	8000	17500	8000	25847	11722	
		V400	159.1	4040	125.0	3175	210.6	5348	210.6	5350	5.9	150	5.9	150	15	10	17500	8000	17500	8000	25955	11771	
		V450	178.7	4540	136.8	3475	230.2	5848	230.3	5850	5.9	150	5.9	150	15	10	17500	8000	17500	8000	26429	11986	
		V500	198.4	5040	146.7	3725	249.9	6348	250.0	6350	5.9	150	5.9	150	15	10	17500	8000	17500	8000	26609	12067	
		V550	218.1	5540	156.5	3975	269.6	6848	269.7	6850	5.9	150	5.9	150	15	10	17500	8000	16979	7700	26788	12149	
		V600	237.8	6040	166.3	4225	289.3	7348	289.4	7350	5.9	150	5.9	150	15	10	17420	7900	16538	7500	26969	12231	
	V700	277.2	7040	186.0	4725	328.7	8348	328.7	8350	5.9	150	5.9	150	15	6	16538	7500	15656	7100	27421	12436		
	V750	296.9	7540	195.9	4975	348.3	8848	348.4	8850	5.9	150	5.9	150	15	6	16097	7300	15215	6900	27606	12520		
	3-STAGE FULL FREE LIFT	TF/TS 450	179.9	4570	108.3	2750	232.4	5902	231.5	5880	55.8	1418	56.7	1440	15	10	17500	8000	17500	8000	27055	12270	
TF/TS 500		199.6	5070	116.1	2950	252.0	6402	251.2	6380	63.7	1618	64.6	1640	15	10	17500	8000	17200	7800	27282	12373		
TF/TS 550		223.2	5570	124.0	3150	271.7	6902	270.9	6880	71.6	1818	72.4	1840	15	10	17500	8000	16759	7600	27507	12475		
TF/TS 600		239.0	6070	131.9	3350	291.4	7402	290.6	7380	79.4	2018	80.3	2040	15	10	17200	7800	16318	7400	27734	12578		

Option : Shaft Type Fork & Carriage

Model	Mast Type	Maximum Fork height		Overall Height								Free Lift				Tilt Angle		Load capacity w/o side shift At 24 in (600mm)LC		Load capacity w/integral side shift At 24 in (600mm)LC		TRUCK WEIGHT UNLOADED	
				Low ered				Extended				Without Load Backrest		With Std Load Backrest		Fwd deg	Bwd deg	lb	kg	lb	kg	lb	kg
				in	mm	in	mm	in	mm	in	mm	in	mm	in	mm								
80D-9	2-STAGE LIMITED FREE LIFT	V270	107.9	2740	99.4	2525	160.4	4075	160.4	4075	5.9	150	5.9	150	15	10	17500	8000	17500	8000	25461	11547	
		V300	119.7	3040	105.3	2675	172.2	4375	172.2	4375	5.9	150	5.9	150	15	10	17500	8000	17500	8000	25569	11596	
		V330	131.5	3340	111.2	2825	184.1	4675	184.1	4675	5.9	150	5.9	150	15	10	17500	8000	17500	8000	25677	11645	
		V350	139.4	3540	115.2	2925	191.9	4875	191.9	4875	5.9	150	5.9	150	15	10	17500	8000	17500	8000	25750	11678	
		V370	147.2	3740	119.1	3025	199.8	5075	199.8	5075	5.9	150	5.9	150	15	10	17500	8000	17500	8000	25820	11710	
		V400	159.1	4040	125.0	3175	211.6	5375	211.6	5375	5.9	150	5.9	150	15	10	17500	8000	17500	8000	25928	11759	
		V450	178.7	4540	136.8	3475	231.3	5875	231.3	5875	5.9	150	5.9	150	15	10	17500	8000	17500	8000	26402	11974	
		V500	198.4	5040	146.7	3725	251.0	6375	251.0	6375	5.9	150	5.9	150	15	10	17500	8000	17420	7900	26582	12055	
		V550	218.1	5540	156.5	3975	270.7	6875	270.7	6875	5.9	150	5.9	150	15	10	17500	8000	16979	7700	26762	12137	
		V600	237.8	6040	166.3	4225	290.4	7375	290.4	7375	5.9	150	5.9	150	15	10	17420	7900	16318	7400	26943	12219	
	V700	277.2	7040	186.0	4725	329.7	8375	329.7	8375	5.9	150	5.9	150	15	6	16538	7500	15436	7000	27395	12424		
	V750	296.9	7540	195.9	4975	349.4	8875	349.4	8875	5.9	150	5.9	150	15	6	16097	7300	14994	6800	27580	12508		
	3-STAGE FULL FREE LIFT	TF/TS 450	179.9	4570	108.3	2750	232.5	5905	232.5	5905	55.7	1415	56.6	1415	15	10	17500	8000	17500	8000	26998	12244	
TF/TS 500		199.6	5070	116.1	2950	252.2	6405	252.2	6405	63.6	1615	64.5	1615	15	10	17500	8000	17200	7800	27225	12347		
TF/TS 550		223.2	5570	124.0	3150	271.9	6905	271.9	6905	71.5	1815	72.4	1815	15	10	17500	8000	16759	7600	27450	12449		
TF/TS 600		239.0	6070	131.9	3350	291.5	7405	291.5	7405	79.3	2015	80.2	2015	15	10	17200	7800	16318	7400	27677	12552		

## Load Capacity



## Various Attachments

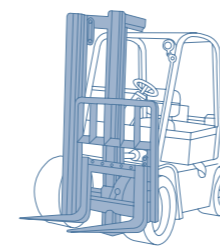

Side Shift

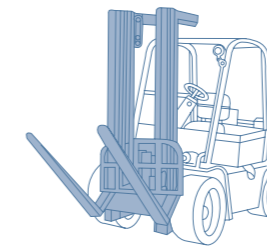

Hinged Fork

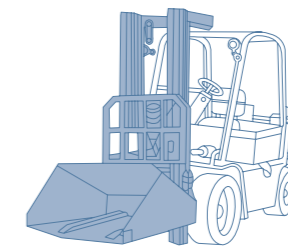

Hinged Bucket

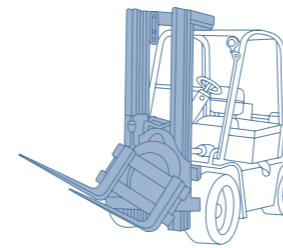

Rotating Fork

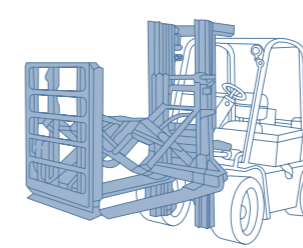

Push Pull

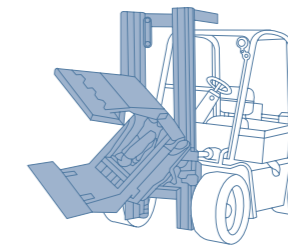

Rotating Roll Clamp

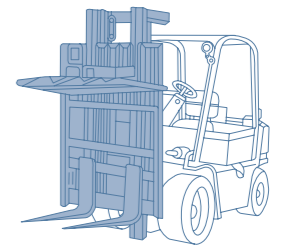

Load Stabilizer

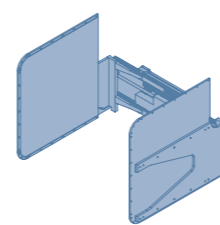

Carton Clamp

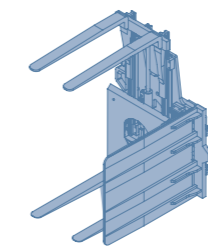

Pallet Invert

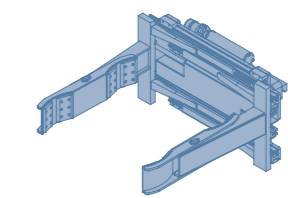

Drum Clamp

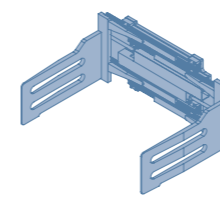

Bale Clamp

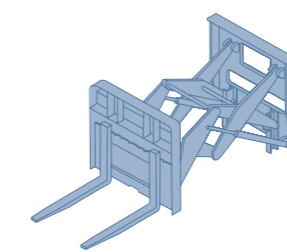

Load Extender

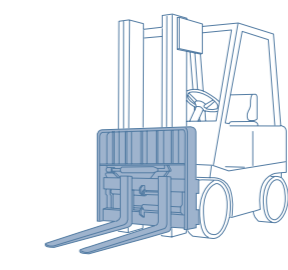

Fork Positioner

## Optional Items

### · FORK (L x W x T) (mm)

#### HOOK TYPE

80D-9 · 1,350 x 180 x 70 · 1,500 x 180 x 70 · 1,800 x 180 x 70  
· 2,000 x 180 x 70 · 2,400 x 180 x 70

#### SHAFT TYPE

80D-9 · 1,350 x 180 x 70 · 1,500 x 180 x 70 · 1,800 x 180 x 70  
· 2,000 x 180 x 70 · 2,400 x 180 x 70

### · TIRE SOLID

#### · SEAT ARM REST, HEAT, BACKREST EXT, BUCKLE SW

#### · CABIN & HEATER CABIN, AIRCON+HEATER

#### · MASTER SWITCH

#### · BEACON LAMP

#### · MCV 3-SPOOL / 4-SPOOL / 5-SPOOL

#### · INTEGRAL FORK POSITIONER CARRIAGE (SHAFT TYPE)

### · INTEGRAL SIDE SHIFT CARRIAGE (SHAFT TYPE)

#### · INTEGRAL SIDE SHIFT WITH FORK POSITIONER CARRIAGE (SHAFT TYPE)

#### · OPSS (TRAVEL OR TRAVEL + MAST)

#### · REAR VIEW CAMERA

#### · LOAD INDICATOR

#### · 3STAGE FULL FREE LIFT DUAL FREE CYL TYPE

## Dimension

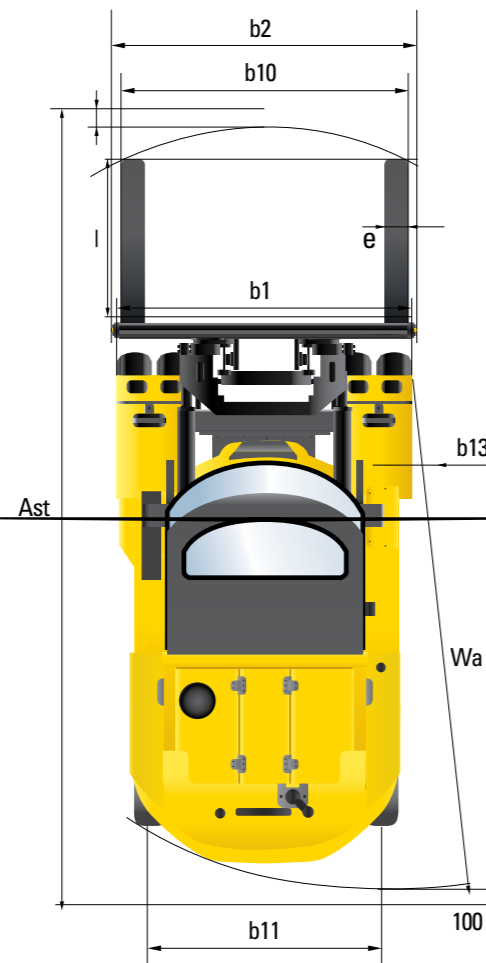
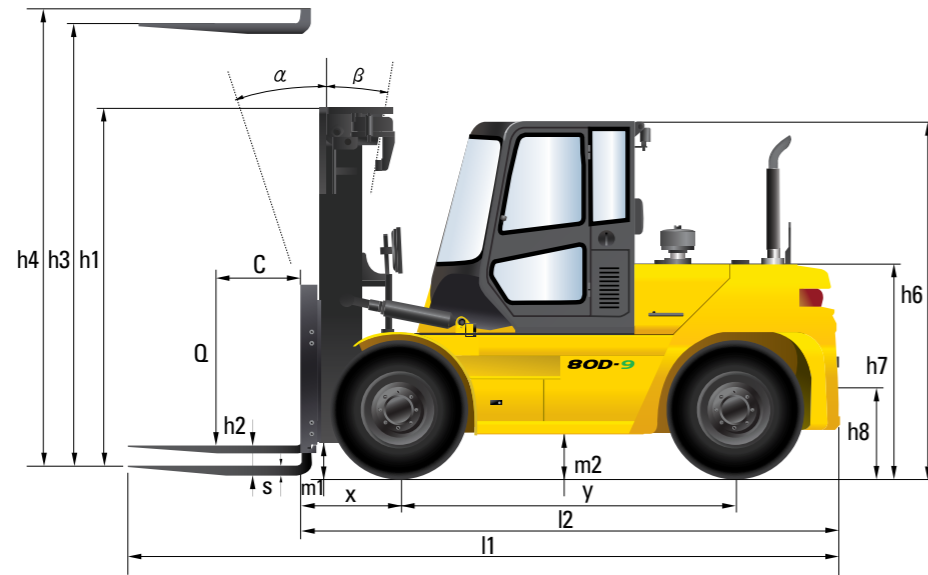

## Specification

Identification		80D-9
1.1	Manufacturer	Hyundai
1.2	Manufacturer's model designation	80D-9
1.3	Drive:electric (battery or mains), diesel, petrol, fuel gas, manual	DIESEL
1.4	Type of operation:hand, pedestrian, standing, seated, order-picker	seated
1.5	Load capacity / rated load	kg 8,000
1.7	Load center distance	c mm 600
1.8	Load distance, center of drive axle to fork	x mm 690
1.9	Wheelbase	y mm 2,500
Weights		
2.1	Service weight	kg 11,608
2.2	Axle loading, loaded front/rear	kg 17,258 / 2,442
2.3	Axle loading, unloaded front/rear	kg 5,130 / 6,570
Wheels, Chassis		
3.1	Tires:solid rubber, superelastic, pneumatic, polyurethane	pneumatic
3.2	Tires size, front	9.00-20-14PR
3.3	Tires size, rear	9.00-20-14PR
3.5	Number of wheels front / rear (x=driven)	4 x / 2
3.6	Track width, front	b10 mm 1,632
3.7	Track width, rear	b11 mm 1,700
Basic Dimensions		
4.1	Mast / fork carriage tilt forward / backward	alpha/beta degree 15° / 10°
4.2	Lowered mast height	h1 mm 2,675
4.3	Free lift	h2 mm 145
4.4	Lift height	h3 mm 3,040
4.5	Extended mast height	h4 mm 4,375
4.7	Overhead guard height	h6 mm 2,640
4.8	Seat height / standing height rel. to SIP	h7 mm 1,650
4.12	Coupling height	h10 mm 508
4.19	Overall length	l1 mm 5,316
4.20	Length to face of forks	l2 mm 3,971
4.21	Overall width	b1 mm 2,194
4.22	Fork dimensions	s/e/l mm 70 x 180 x 1200
4.23	Fork carriage ISO 2328, class / type A,B	Class IV
4.24	Fork-carriage width	b2 mm 2,268
4.31	Ground clearance under mast, loaded	m1 mm 250
4.32	Ground clearance center of wheelbase	m2 mm 302
4.33	Aisle width for pallets 1,000 x 1,200 crossways (L x W)	Ast mm 5,590
4.34	Aisle width for pallets 800 x 1,200 lengthways (W x L)	Ast mm 5,790
4.35	Turning radius	Wa mm 3,700
4.36	Smallest pivot point distance	b13 mm 1,354
Performance Data		
5.1	Travel speed, unloaded	km/h 35
5.2	Lift speed, loaded / unloaded	mm/s 410 / 480
5.3	Lowering speed, loaded / unloaded	mm/s 500 / 500
5.5	Max drawbar pull, loaded	N 70,010
5.7	Gradeability, loaded	% 35.2
5.10	Service brake	FOOT(Hydraulic)
Engine		
6.1	Engine manufacturer / type	CUMMINS / QSF3.8
6.2	Engine power acc. To ISO 1585	kW/rpm 75KW(102ps)/2200
6.3	Maximum torque	kgf-m/rpm 42.3/1600
6.4	No. of cylinder / displacement	/ cc 4/3800
6.5	Fuel consumption acc. To VDI cycle	l/h 8.5
Other Details		
8.1	Type of drive control	Full Auto
8.2	Operating pressure (system / attach)	kg/cm <sup>2</sup> 210 / 150
8.3	Oil volume (hydraulic)	l 115
8.4	Sound level (at driver's ear according to DIN 12 053)	dB(A) 78.6
8.5	Trailer coupling, type DIN	Pin

### Air Conditioning System

The air condition system for the machine contains the fluorinated greenhouse gas with global warming potential of R134a. (Global Warming Potential : 1430)  
The system hold 0.55kg refrigerant consisting of a CO<sub>2</sub> equivalent 0.79kg metric tonne.  
For more information, Please refer to the manual.